

Introduction

DZ series servo drives are designed for direct PCB integration. This feature can be utilized either by soldering the drive directly to the user PCB board, or through the use of a mounting card. **ADVANCED Motion Controls** supplies mounting cards pre-designed for use with the DZ drive family, or the user can opt to design their own. This document outlines some key features that must be kept in mind while designing an interface card for use with DZ drives.

Note: This application note is designed to be used in conjunction with the appropriate data sheet of the servo drive the interface card is being designed for.

Address Line Voltage Levels

The address lines on the DZ drive series are sensitive to voltage level. Voltages slightly above 3V can lead to damage of the drive. The user's interface card must be designed to take this into consideration, and ensure voltages greater than 3V are not applied to the address lines.

Note 1: Be sure not to apply voltages greater than 3V to the address lines. Consult the drive's datasheet for exact voltage levels.

Note 2: The address lines should not be left floating. They should either have a voltage applied to them or be grounded (grounding both address lines will use the default address that is stored in non-volatile memory).

Address Line Inputs

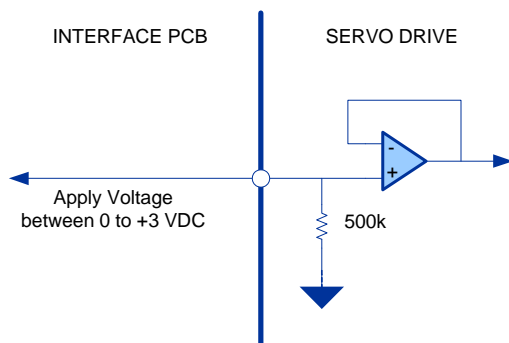

CAN Transceiver

For DZ drives with CANopen interface, the CAN transceiver is not supplied on the drive. A CAN transceiver and additional circuitry must be provided on the user's interface card.

Note: The DZ drive with RS232/485 interface does not require a CAN transceiver

Recommended CAN Transceiver

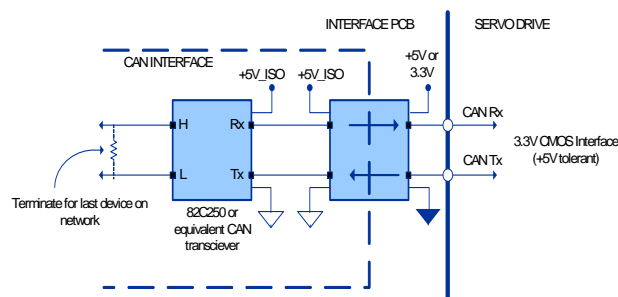

RS-232/485 Interface

The below diagram is an example of how the DZ drive series RS-232/485 connections should connect to a mounting card/interface PCB.

Note 1: For RS-485 communication, a jumper must be installed between +5V and the 232/485 select pin.

Note 2: The DZ with CANopen interface only supports RS232.

Recommended RS-232/485 Interface

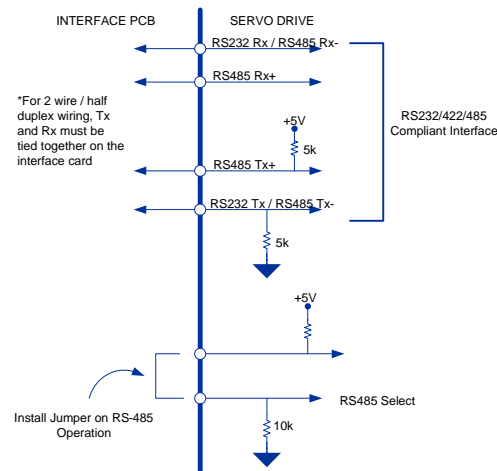

Digital Inputs (High Speed)

The DZ drive series provides differential programmable digital inputs. These inputs can be used for Capture, Step & Direction, or Auxiliary Encoder inputs. The below diagram is an example of how the mounting card/interface board should be designed for proper operation.

Recommended Digital Inputs Interface

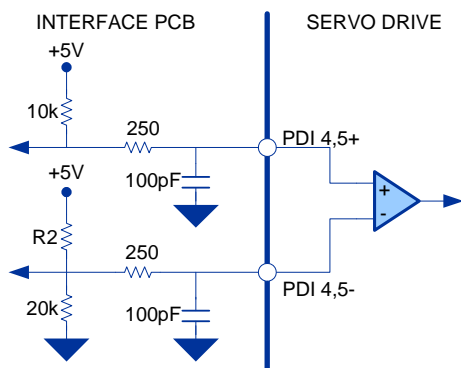

Note: R2 is only needed for single-ended operation.

Digital Inputs (Standard)

The DZ drive series provides single-ended TTL level programmable digital inputs. The below diagram is an example of how the mounting card/interface PCB should be designed for proper operation.

Recommended Digital Inputs Interface

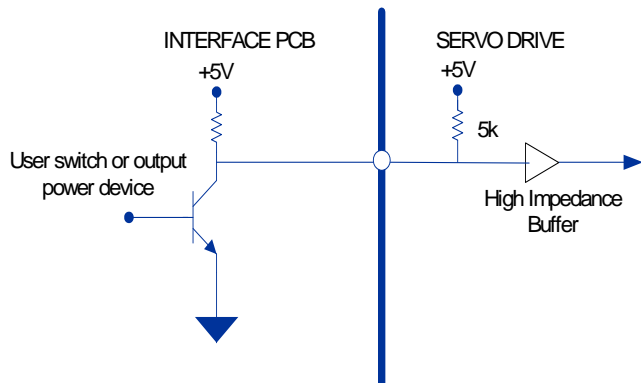

Digital Outputs

The DZ drive series provides single-ended programmable digital outputs. The below diagram is an example of how the mounting card/interface PCB should be designed for proper operation.

Sinking Digital Output

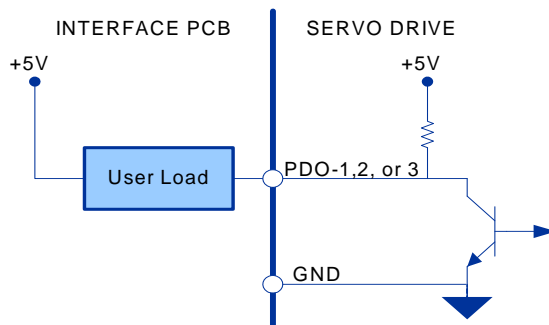

Analog Inputs

The DZ drive series provides programmable analog inputs. The below diagram is an example of how the mounting card/interface PCB should be designed for proper operation.

Recommended Analog Input Interface

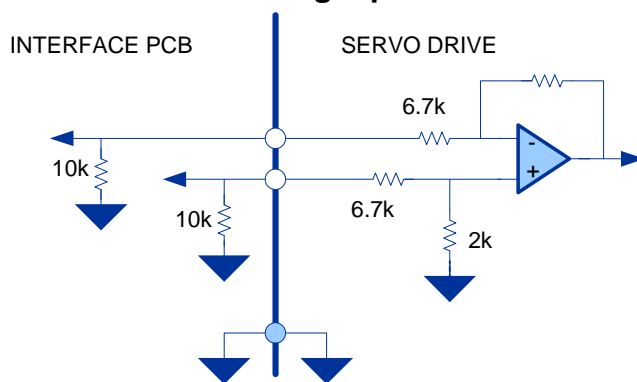

Note: For single-ended use, ground the non-inverting input.

Hall Sensors

The DZ drive series allows either differential or single-ended Hall Sensor inputs. For single-ended Halls no additional circuitry is required. For differential Halls, the inputs must first go through a signal conditioning amplifier. Users designing their own mounting card or interface PCB must be sure to include this feature in their design.

Recommended Hall Sensor Interface

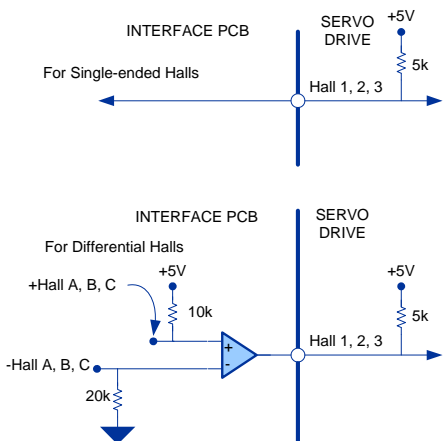

Encoder Support

The DZ series drive supports differential encoder inputs. The encoder inputs are not filtered on the drive. Users designing their own interface card must provide this circuitry on their interface card. Below is the recommended interface circuitry.

Recommended Encoder Interface

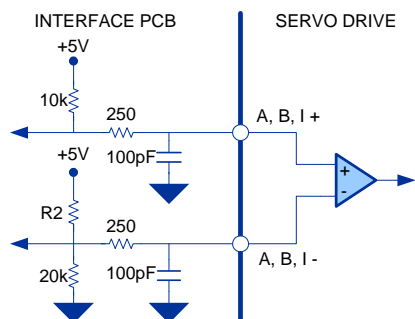

Note: R2 is only needed for single-ended operation.

DC Input Power

The diagram below shows how the DZ drive series connects to an isolated DC Power Supply through a mounting card/interface PCB. Notice that the power supply wires are shielded, and that the power supply, shield, and interface PCB are all grounded at the same point.

Recommended DC Power Interface

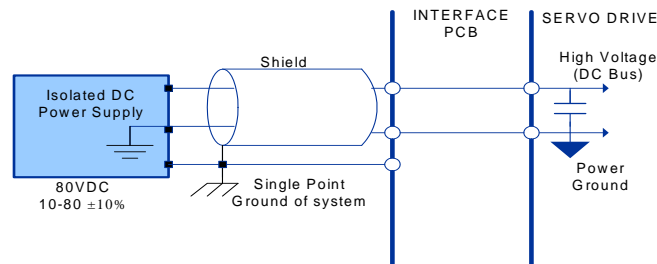

Note: Depending on the power capacity of the drive model being used there may be multiple pins for DC Input Power connections. Refer to the datasheet of the specific model being used. The maximum current capacity per pin is 3A continuous.

Motor Power

The diagram below shows how the DZ drives series connects to a motor through a mounting card/interface PCB. Both brush-type and brushless motors should follow this general setup. Notice that the motor wires are shielded, and that both the interface PCB, the motor housing, and the shield are grounded at the same point.

Recommended Motor Power Interface

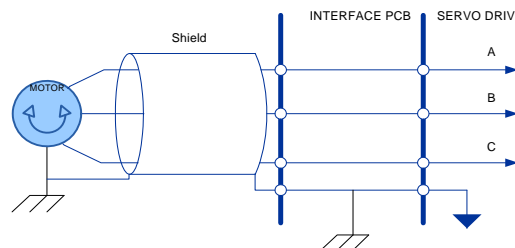

Note: Depending on the power capacity of the drive model being used there may be multiple pins for Motor Power connections. Refer to the datasheet of the specific model being used. The maximum current capacity per pin is 3A continuous.