

Description

The 25A20 PWM servo drive is designed to drive brush type DC motors at a high switching frequency. A single red/green LED indicates operating status. The drive is fully protected against over-voltage, under voltage, over-current, over-heating and short-circuits across motor, ground and power leads. Furthermore, the drive can interface with digital controllers or be used stand-alone and requires only a single unregulated DC power supply. Loop gain, current limit, input gain and offset can be adjusted using 14-turn potentiometers. The offset adjusting potentiometer can also be used as an on-board input signal for testing purposes.

Power Range

Peak Current	25 A
Continuous Current	12.5 A
Supply Voltage	40 - 190 VDC

Features

- ▲ Four Quadrant Regenerative Operation
- ▲ DIP Switch Selectable Modes
- ▲ Adjustable Current Limits
- ▲ High Switching Frequency
- ▲ Differential Input Command
- ▲ Digital Fault Output Monitor
- ▲ On-Board Test Potentiometer
- ▲ Offset Adjustment Potentiometer
- ▲ Adjustable Input Gain
- ▲ Drive Status LED
- ▲ Current Monitor Output
- ▲ Directional Inhibit Inputs for Limit Switches

MODES OF OPERATION

- Current
- Tachometer Velocity
- Voltage
- IR Compensation

COMMAND SOURCE

- ± 10 V Analog

FEEDBACK SUPPORTED

- Tachometer

COMPLIANCES & AGENCY APPROVALS

- UL
- cUL
- CE Class A (LVD)
- CE Class A (EMC)
- RoHS

BLOCK DIAGRAM

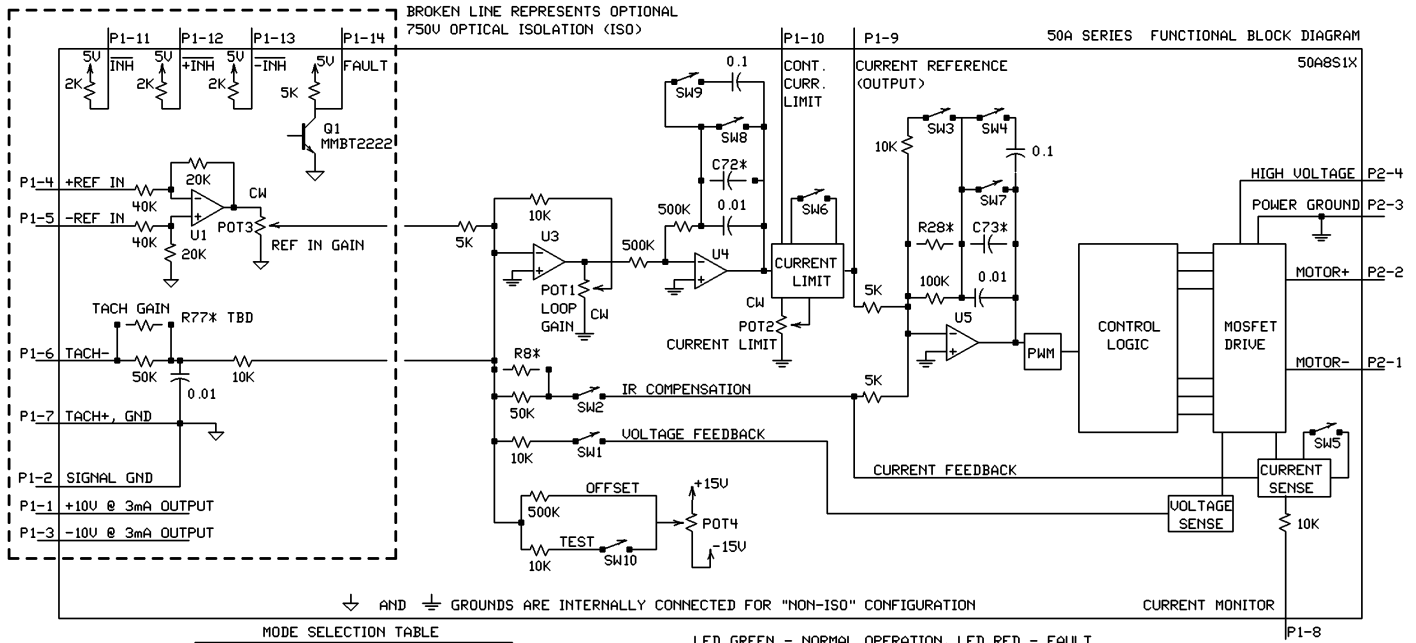

MODE SELECTION TABLE

	SW1	SW2	SW3	SW4	SW7	SW8	SW9
CURRENT MODE	OFF	OFF	ON	OFF	OFF	ON	OFF
VOLTAGE MODE	ON	OFF	ON	OFF	OFF	OFF	OFF
IR COMPENSATION	ON	ON	ON	OFF	OFF	OFF	OFF
TACHOMETER MODE	OFF	OFF	ON	OFF	OFF	OFF	OFF

SW7 SHOULD BE OFF FOR MOST APPLICATIONS

LED GREEN - NORMAL OPERATION, LED RED - FAULT

RECOMMENDED SETTING FOR CURRENT MODE - POT1 FULLY CCW, POT3 FULLY CW
FOR OTHER SWITCH FUNCTIONS SEE SWITCH DESCRIPTIONS.
AMPLIFIERS ARE SHIPPED IN CURRENT MODE WITH MAXIMUM CURRENT SETTINGS
* OPTIONAL USER INSTALLED THROUGH HOLE COMPONENT

Information on Approvals and Compliances



US and Canadian safety compliance with UL 508c, the industrial standard for power conversion electronics. UL registered under file number E140173. Note that machine components compliant with UL are considered UL registered as opposed to UL listed as would be the case for commercial products.



Compliant with European CE for both the Class A EMC Directive 89/336/EEC on Electromagnetic Compatibility (specifically EN 61000-6-4:2001, EN 61000-6-2:2001, EN 61000-3-2:2000, and EN 61000-3-3:1995/A1:2001) and LVD requirements of directive 73/23/EEC (specifically EN 60204-1), a low voltage directive to protect users from electrical shock.



RoHS (Reduction of Hazardous Substances) is intended to prevent hazardous substances such as lead from being manufactured in electrical and electronic equipment.

SPECIFICATIONS

Power Specifications		
Description	Units	Value
DC Supply Voltage Range	VDC	40 - 190
DC Bus Over Voltage Limit	VDC	195
Maximum Peak Output Current ¹	A	25
Maximum Continuous Output Current	A	12.5
Maximum Power Dissipation at Continuous Current	W	119
Minimum Load Inductance (Line-To-Line) ²	μH	250
Switching Frequency	kHz	22
Control Specifications		
Description	Units	Value
Command Sources	-	±10 V Analog
Feedback Supported	-	Tachometer
Modes of Operation	-	Current, IR Compensation, Tachometer Velocity, Voltage
Motors Supported	-	Single Phase (Brushed, Voice Coil, Inductive Load)
Hardware Protection	-	Over Current, Over Temperature, Over Voltage, Short Circuit (Phase-Phase & Phase-Ground)
Mechanical Specifications		
Description	Units	Value
Agency Approvals	-	CE Class A (EMC), CE Class A (LVD), cUL, RoHS, UL
Size (H x W x D)	mm (in)	186.7 x 111.7 x 25.4 (7.4 x 4.4 x 1)
Weight	g (oz)	680 (24)
Heatsink (Base) Temperature Range ³	°C (°F)	0 - 65 (32 - 149)
Storage Temperature Range	°C (°F)	-40 - 85 (-40 - 185)
Form Factor	-	Stand Alone
P1 Connector	-	16-pin, 2.54 mm spaced, friction lock header
P2 Connector	-	4-contact, 11.10 mm spaced, tri-barrier terminal block

Notes

1. Maximum duration of peak current is ~2 seconds.
2. Lower inductance is acceptable for bus voltages well below maximum. Use external inductance to meet requirements.
3. Additional cooling and/or heatsink may be required to achieve rated performance.

PIN FUNCTIONS

P1 - Signal Connector			
Pin	Name	Description / Notes	I/O
1	+10V 3mA OUT	±10 V @ 3 mA low power supply for customer use. Short circuit protected. Reference ground common with signal ground.	O
2	SIGNAL GND		GND
3	-10V 3mA OUT		O
4	+REF IN	Differential Reference Input (±10 V Operating Range, ±15 V Maximum Input)	I
5	-REF IN		I
6	-TACH IN	Negative Tachometer Input (Maximum ±60 V). Use signal ground for positive input.	I
7	+TACH / GND	Positive Tachometer Input and Signal Ground	GND
8	CURR MONITOR OUT	Current Monitor. Analog output signal proportional to the actual current output. Scaling is 3.8 A/V by default but may be reduced to half this value by setting DIP switch SW-5 to OFF (see Hardware Settings section below). Measure relative to signal ground.	O
9	CURRENT REF OUT	Measures the command signal to the internal current-loop. This pin has a maximum output of ±7.25 V when the drive outputs maximum peak current. Measure relative to signal ground.	O
10	CONT CURRENT LIMIT	Can be used to reduce the factory-preset maximum continuous current limit without affecting the peak current limit by attaching an external current limiting resistor between this pin and signal ground. See pin details below for resistor values.	I
11	INHIBIT IN	TTL level (+5 V) inhibit/enable input. Leave open to enable drive. Pull to ground to inhibit drive. Inhibit turns off all power devices.	I
12	+INHIBIT IN	Positive Direction Inhibit (Does Not Cause A Fault Condition)	I
13	-INHIBIT IN	Negative Direction Inhibit (Does Not Cause A Fault Condition)	I
14	FAULT OUT	TTL level (+5 V) output becomes high when power devices are disabled due to at least one of the following conditions: inhibit, output short circuit, over voltage, over temperature, power-up reset.	O
15	SYNCH IN	Used for synchronizing the switching frequency of several amplifier modules. Consult factory for this option.	-
16	SYNCH OUT		-

P2 - Power Connector			
Pin	Name	Description / Notes	I/O
1	-MOT	Negative Motor Output	O
2	+MOT	Positive Motor Output	O
3	PWR GND	Power Ground (Common With Signal Ground)	GND
4	HIGH VOLT	DC Power Input	I

Pin Details

CONT CURRENT LIMIT (P1-10)

This pin can be used to reduce the continuous current limit without affecting the peak current limit by connecting an external current limiting resistor between this pin and signal ground. See table below.

Current Limit Resistor	18 kΩ	6.5 kΩ	3.4 kΩ	2.5 kΩ	1.8 kΩ	1 kΩ	800 Ω	300 Ω	0 kΩ
Continuous Current Limit	90%	80%	70%	65%	60%	50%	45%	40%	30%

Note: These values are secondary to the continuous/peak ratio set by the DIP switches.

HARDWARE SETTINGS

Switch Functions

Switch	Description	Setting	
		On	Off
1	Voltage feedback. Mode dependent (see mode selection table below).	On	Off
2	IR compensation. Activates or deactivates IR feedback. ON for IR compensation mode and OFF for other modes.	On	Off
3	Current loop proportional gain adjustment. ON by default.	Decrease	Increase
4	Inner (current) loop integral gain adjustment. OFF by default.	Decrease	Increase
5	Current scaling. When OFF, increases sensitivity of current sense thus reducing both peak and continuous current limit by 50%. The scaling of the current monitor output signal becomes ½ its ordinary value when this switch is OFF.	Full-current	Half-current
6	Current limit ratio. Used to set continuous-to-peak current limit ratio. Default is OFF.	Cont./Peak Ratio = 25%	Cont./Peak Ratio = 50%
7	Current loop integral gain. Activates or deactivates integration. OFF by default.	Inactive	Active
8	Outer loop integration. Activates or deactivates integration. ON, by default, for current mode and OFF for other modes.	Inactive	Active
9	Outer loop integral gain adjustment. It is recommended to leave this switch OFF for most applications.	Decrease	Increase
10	Test/Offset. Switches the function of the Test/Offset pot between an on-board command input for testing or a command offset adjustment. OFF by default.	Test	Offset

Mode Selection Table

	SW1	SW2	SW3	SW4	SW7	SW8	SW9
CURRENT	OFF	OFF	ON	OFF	OFF	ON	OFF
VOLTAGE	ON	OFF	ON	OFF	OFF	OFF	OFF
IR COMPENSATION	ON	ON	ON	OFF	OFF	OFF	OFF
TACHOMETER	OFF	OFF	ON	OFF	OFF	OFF	OFF

Note: SW7 should be off for most applications

Potentiometer Functions

Potentiometer	Description	Turning CW
1	Loop gain adjustment for voltage/velocity modes. Turn this pot fully CCW in current mode.	Increases gain
2	Current limit. It adjusts both continuous and peak current limit while maintaining their ratio.	Increases limit
3	Reference gain. Adjusts the ratio between input signal and output variables (voltage, current, or velocity).	Increases gain
4	Offset / Test. Used to adjust any imbalance in the input signal or in the amplifier. Can also be used as an on-board signal source for testing purposes.	Adjusts offset in negative direction

Note: Potentiometers are approximately linear and have 12 active turns with 1 inactive turn on each end.

Through-hole Components[†]

Location	Description
C72*	Velocity Loop Integrator. Through-hole capacitor that can be added for more precise velocity loop tuning. See section below on Tuning with Through-hole components for more details.
C73*	Current Loop Integrator. Through-hole capacitor that can be added for more precise current loop tuning. See section below on Tuning with Through-hole components for more details.
R28*	Current Loop Proportional Gain. Through-hole resistor that can be added for more precise current loop tuning. See section below on Tuning with Through-hole components for more details.
R77*	Tachometer Input Scaling. Through-hole resistor that can be added to change the gain of the tachometer input. See section below on Tachometer Gain for more details.
R8*	IR Compensation Scaling. Through-hole resistor that can be added to configure the amplifier for IR Compensation mode. See section below on IR Compensation Notes for more details.

Tuning With Through-hole Components

In general, the drive will not need to be further tuned with through-hole components. However, for applications requiring more precise tuning than what is offered by the potentiometers and dipswitches, the drive can be manually modified with through-hole resistors and capacitors as denoted in the above table. By default, the through-hole locations are not populated when the drive is shipped. Before attempting to add through-hole components to the board, consult the section on loop tuning in the installation notes on the manufacturer's website. Some general rules of thumb to follow when adding through-hole components are:

- A larger resistor value will increase the proportional gain, and therefore create a faster response time.
- A larger capacitor value will increase the integration time, and therefore create a slower response time.

Proper tuning using the through-hole components will require careful observation of the loop response on a digital oscilloscope to find the optimal through-hole component values for the specific application.

Tachometer Gain

Some applications may require an increase in the gain of the tachometer input signal. This occurrence will be most common in designs where the tachometer input has a low voltage to RPM scaling ratio. The drive offers a through-hole location listed in the above table where a resistor can be added to increase the tachometer gain. Use the drive's block diagram to determine an appropriate resistor value.

IR Compensation Notes

For applications that will use IR Compensation mode, a resistor can be added to the location named in the table above. The combination of the added resistor and correct dipswitch settings will configure the amplifier for IR Compensation mode. While in IR Compensation mode, the amplifier will adjust the duty cycle to compensate for changes in the output current. Consult the amplifier's functional block diagram and the manufacturer's website for more information.

[†]Note: Damage done to the drive while performing these modifications will void the warranty.

MECHANICAL INFORMATION

P1 - Signal Connector

Connector Information		16-pin, 2.54 mm spaced, friction lock header
Mating Connector	Details	Molex: P/N 22-01-3167 (connector) and P/N 08-50-0114 (insert terminals)
	Included with Drive	Yes

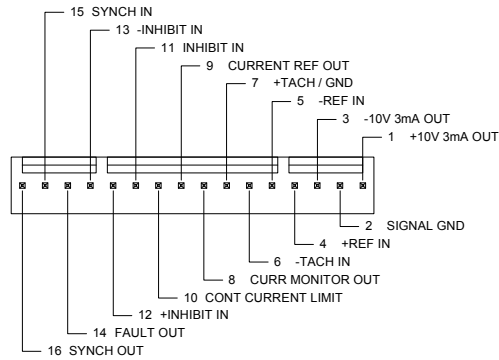

P2 - Power Connector

Connector Information		4-contact, 11.10 mm spaced, tri-barrier terminal block
Mating Connector	Details	Not applicable
	Included with Drive	Not applicable

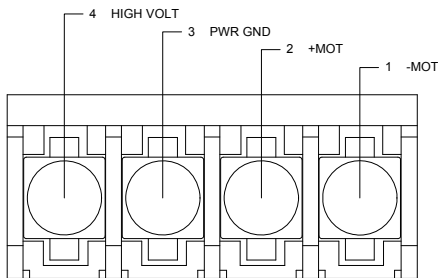

MOUNTING DIMENSIONS

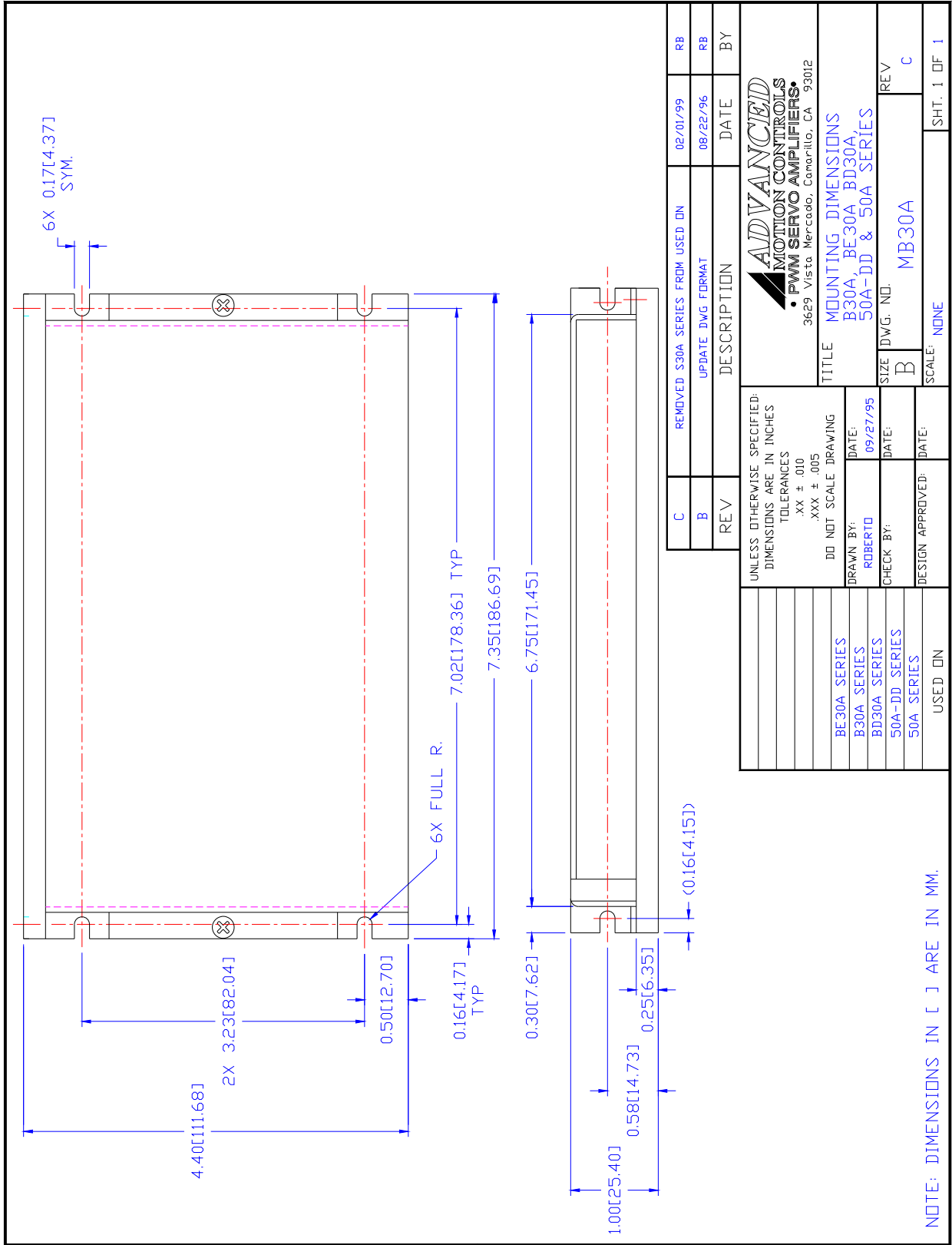

C	REMOVED S30A SERIES FROM USED ON	02/01/99	RB
B	UPDATE DWG FORMAT	08/22/96	RB
REV	DESCRIPTION	DATE	BY

<p>ADVANCED MOTION CONTROLS • PWM SERVO AMPLIFIERS 3629 Vista Merced, Camarillo, CA 93012</p>	
<p>TITLE: MOUNTING DIMENSIONS B30A, BE30A, BD30A, 50A-DD & 50A SERIES</p>	
SIZE: B	DWG. NO: MB30A
REV: C	
SCALE: NONE	SHT. 1 OF 1

NOTE: DIMENSIONS IN [] ARE IN MM.

PART NUMBERING INFORMATION

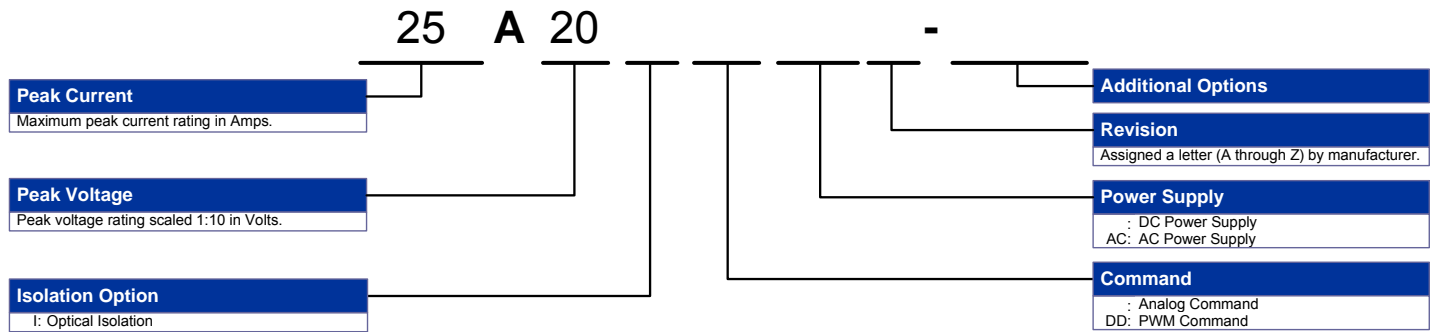

ADVANCED Motion Controls servo drives are available in many configurations. All models listed in the selection tables of the website are readily available, standard product offerings.

ADVANCED Motion Controls also has the capability to promptly develop and deliver specified products for OEMs with volume requests. Our Applications and Engineering Departments will work closely with your design team through all stages of development in order to provide the best servo drive solution for your system. Equipped with on-site manufacturing for quick-turn customs capabilities, ADVANCED Motion Controls utilizes our years of engineering and manufacturing expertise to decrease your costs and time-to-market while increasing system quality and reliability.

Examples of Customized Products

- ▲ Integration of Drive into Motor Housing
- ▲ Mount OEM PCB onto Drive Without Cables
- ▲ Multi-axis Configuration for Compact System
- ▲ Custom PCB and Baseplate for Optimized Footprint
- ▲ RTV/Epoxy Components for High Vibration
- ▲ OEM Specified Connectors for Instant Compatibility
- ▲ OEM Specified Silkscreen for Custom Appearance
- ▲ Increased Thermal Limits for High Temp. Operation
- ▲ Integrate OEM Circuitry onto Drive PCB
- ▲ Custom Control Loop Tuned to Motor Characteristics
- ▲ Custom I/O Interface for System Compatibility
- ▲ Preset Switches and Pots to Reduce User Setup
- ▲ Optimized Switching Frequency
- ▲ Ramped Velocity Command for Smooth Acceleration
- ▲ Remove Unused Features to Reduce OEM Cost
- ▲ Application Specific Current and Voltage Limits

Feel free to contact Applications Engineering for further information and details.

Available Accessories

ADVANCED Motion Controls offers a variety of accessories designed to facilitate drive integration into a servo system. Visit www.a-m-c.com to see which accessories will assist with your application design and implementation.

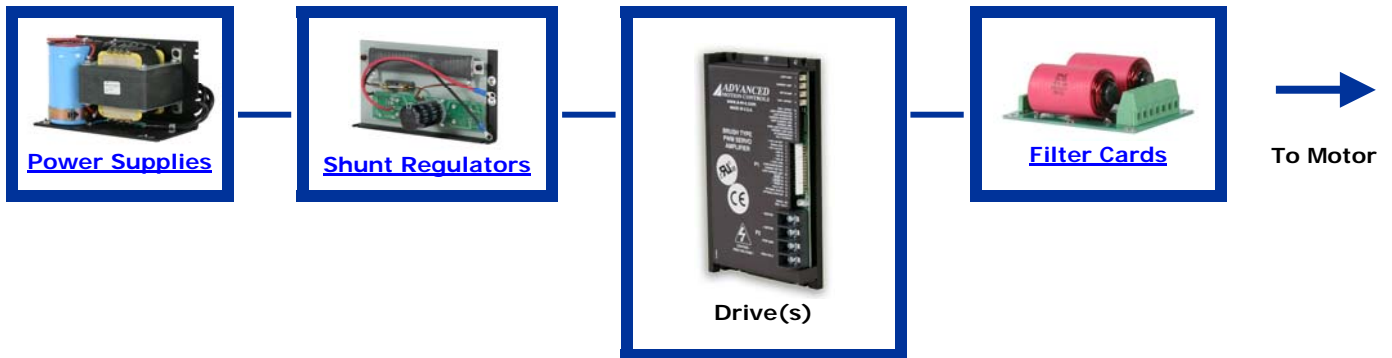

All specifications in this document are subject to change without written notice. Actual product may differ from pictures provided in this document.