

**Description**

The AZXB15A8 PWM servo drive is designed to drive brushless DC motors at a high switching frequency. To increase system reliability and to reduce cabling costs, the drive is designed for direct integration into your PCB. The AZXB15A8 is fully protected against over-voltage, under-voltage, over-current, over-heating, invalid commutation, and short-circuits. A single digital output indicates operating status. The drive interfaces with digital controllers that have analog  $\pm 10V$  output. This servo drive requires only a single unregulated isolated DC power supply, and is fully RoHS (Reduction of Hazardous Substances) compliant.

The AZXB15A8 conforms to the following specifications and is designed to the Environmental Engineering Considerations as defined in MIL-STD-810F.

Extended Environment Performance	
Ambient Temperature	-40°C to +85°C (-40°F to +185°F)
Storage Temperature	-50°C to +100°C (-58°F to +212°F)
Thermal Shock	-40°C to +85°C (-40°F to +185°F) in 2 min.
Relative Humidity	0 to 95% Non-Condensing
Vibration	30 Grms for 5 min. in 3 axes

See Part Numbering Information on last page of datasheet for additional ordering options.

**Power Range**

Peak Current	15 A
Continuous Current	7.5 A
Supply Voltage	10 - 80 VDC



**Features**

- |  |  |
|--|--|
| ▲ High Power Density                   | ▲ Wide Temperature Range               |
| ▲ Compact Size                         | ▲ High Performance Thermal Dissipation |
| ▲ Direct Board-to-Board Integration    | ▲ Differential Input Command           |
| ▲ Lightweight                          | ▲ Current Monitor Output               |
| ▲ High Switching Frequency             | ▲ Digital Fault Output Monitor         |
| ▲ Four Quadrant Regenerative Operation | ▲ 12VDC Operation                      |

**HARDWARE PROTECTION**

- Over-Voltage
- Under-Voltage
- Over-Current
- Over-Temperature
- Short-circuit (phase-phase)
- Short-circuit (phase-ground)

**INPUTS/OUTPUTS**

- Digital Fault Output
- Digital Inhibit Input
- Analog Current Monitor
- Analog Command Input
- Analog Current Reference

**FEEDBACK SUPPORTED**

- Hall Sensors

**MODES OF OPERATION**

- Current

**COMMUTATION**

- Trapezoidal

**MOTORS SUPPORTED**

- Three Phase (Brushless)
- Single Phase (Brushed, Voice Coil, Inductive Load)

**COMMAND SOURCE**

- $\pm 10 V$  Analog



**AGENCY APPROVALS & COMPLIANCE CONSIDERATIONS**

- CE Class A (LVD)
- CE Class A (EMC)
- RoHS
- MIL-STD-810F (as stated)
- MIL-STD-1275D (optional)
- MIL-STD-461E (optional)
- MIL-STD-704F (optional)
- MIL-HDBK-217 (optional)

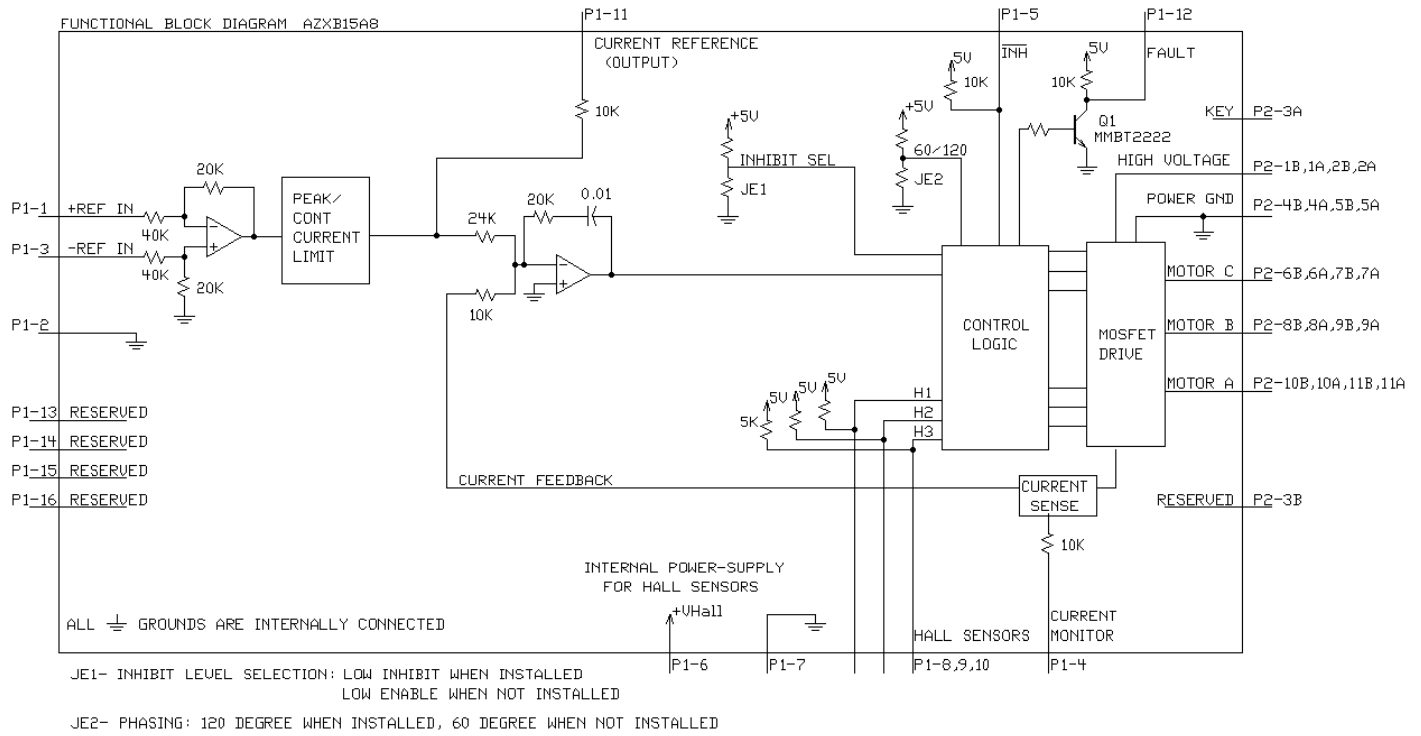
**BLOCK DIAGRAM**



**Information on Approvals and Compliances**

	Compliant with European CE for both the Class A EMC Directive 2004/108/EC on Electromagnetic Compatibility (specifically EN 61000-6-4:2001, EN 61000-6-2:2001, EN 61000-3-2:2000, and EN 61000-3-3:1995/A1:2001) and LVD requirements of directive 2006/95/EC (specifically EN 60204-1), a low voltage directive to protect users from electrical shock.
MIL-STD-810F	Environmental Engineering Considerations and Laboratory Tests – (as stated)
MIL-STD-1275D	Characteristics of 28 Volt DC Electrical Systems in Military Vehicles – (optional)
MIL-STD-461E	Requirements for the Control of Electromagnetic Interference Characteristics of Subsystems and Equipment – (optional)
MIL-STD-704F	Aircraft Electric Power Characteristics – (optional)
MIL-HDBK-217	Reliability Prediction of Electronic Equipment (MTBF) – (optional)
	RoHS (Reduction of Hazardous Substances) is intended to prevent hazardous substances such as lead from being manufactured in electrical and electronic equipment. – (optional)

**SPECIFICATIONS**

Description		Power Specifications		Value
		Units		
DC Supply Voltage Range		VDC	10 - 80	
DC Bus Over Voltage Limit		VDC	88	
DC Bus Under Voltage Limit		VDC	9	
Maximum Peak Output Current <sup>1</sup>		A	15	
Maximum Continuous Output Current		A	7.5	
Maximum Continuous Output Power		W	570	
Maximum Power Dissipation at Continuous Current		W	30	
Minimum Load Inductance (Line-To-Line) <sup>2</sup>		µH	100	
Internal Bus Capacitance <sup>3</sup>		µF	20	
Low Voltage Supply Outputs		-	+6 VDC (30 mA)	
Switching Frequency		kHz	31	
Description		Control Specifications		Value
		Units		
Command Sources		-	±10 V Analog	
Feedback Supported		-	Halls	
Commutation Methods		-	Trapezoidal	
Modes of Operation		-	Current	
Motors Supported		-	Single Phase (Brushed, Voice Coil, Inductive Load), Three Phase (Brushless)	
Hardware Protection		-	Invalid Commutation Feedback, Over Current, Over Temperature, Over Voltage, Under Voltage, Short Circuit (Phase-Phase & Phase-Ground)	
Description		Mechanical Specifications		Value
		Units		
Agency Approvals		-	CE Class A (EMC), CE Class A (LVD), RoHS, MIL-STD-810F (as stated), MIL-STD-1275D (optional), MIL-STD-461E (optional), MIL-STD-704F (optional), MIL-HDBK-217 (optional)	
Size (H x W x D)		mm (in)	63.5 x 50.8 x 22.9 (2.5 x 2 x 0.9)	
Weight		g (oz)	94.5 (3.3)	
Baseplate Operating Temperature Range <sup>4</sup>		°C (°F)	-40 - 105 (-40 - 221)	
Ambient Temperature Range		°C (°F)	-40 - 85 (-40 - 185)	
Storage Temperature Range		°C (°F)	-50 - 100 (-58 - 212)	
Thermal Shock		°C (°F)	-40 - 85 (-40 - 185) in 2 minutes	
Vibration		Grms	30 for 5 minutes in 3 axes	
Relative Humidity		-	0 - 95% Non-Condensing	
Form Factor		-	PCB Mounted	
P1 Connector		-	16-pin, 2.54 mm spaced header	
P2 Connector		-	22-pin, 2.54 mm spaced, dual-row header	

**Notes**

1. Maximum duration of peak current is ~2 seconds.
2. Lower inductance is acceptable for bus voltages well below maximum. Use external inductance to meet requirements.
3. In certain applications with a high source impedance to the drive, an additional 100 µF of external bus capacitance may be required.
4. Additional cooling and/or heatsink may be required to achieve rated performance.

**PIN FUNCTIONS**

P1 - Signal Connector			
Pin	Name	Description / Notes	I/O
1	+REF IN	Differential Reference Input ( $\pm 10$ V Operating Range, $\pm 15$ V Maximum Input)	I
2	SIGNAL GND	Signal Ground	GND
3	-REF IN	Differential Reference Input ( $\pm 10$ V Operating Range, $\pm 15$ V Maximum Input)	I
4	CURRENT MONITOR	Current Monitor. Analog output signal proportional to the actual current output. Scaling is 5.13 A/V. Measure relative to signal ground.	O
5	INHIBIT IN	TTL level (+5 V) inhibit/enable input. Leave open to enable drive. Pull to ground to inhibit drive. Inhibit turns off all power devices.	I
6	+V HALL OUT	Low Power Supply For Hall Sensors (+6 V @ 30 mA). Referenced to signal ground. Short circuit protected.	O
7	SIGNAL GND	Signal Ground	GND
8	HALL 1	Single-ended Hall/Commutation Sensor Inputs (+5 V logic level)	I
9	HALL 2*		I
10	HALL 3		I
11	CURRENT REFERENCE	Measures the command signal to the internal current-loop. This pin has a maximum output of $\pm 7.45$ V when the drive outputs maximum peak current. Measure relative to signal ground.	O
12	FAULT OUT	TTL level (+5 V) output becomes high when power devices are disabled due to at least one of the following conditions: inhibit, invalid Hall state, output short circuit, over voltage, over temperature, power-up reset.	O
13	NC	Not Connected (Reserved)	-
14	NC		-
15	NC		-
16	NC		-

P2 - Power Connector			
Pin	Name	Description / Notes	I/O
1b	1a	HIGH VOLTAGE	DC Power Input. 3A Continuous Current Rating Per Pin. (For applications with a high source impedance, connect external capacitance between High Voltage and Power Ground)
2b	2a	HIGH VOLTAGE	
3b		NC	-
	3a	NC (KEY)	-
4b	4a	PWR GND	Power Ground (Common With Signal Ground). 3A Continuous Current Rating Per Pin
5b	5a	PWR GND	
6b	6a	MOTOR C	Motor Phase C. 3A Continuous Current Rating Per Pin.
7b	7a	MOTOR C	O
8b	8a	MOTOR B*	Motor Phase B. 3A Continuous Current Rating Per Pin.
9b	9a	MOTOR B*	O
10b	10a	MOTOR A*	Motor Phase A. 3A Continuous Current Rating Per Pin.
11b	11a	MOTOR A*	O

\*For use with Single Phase (Brushed) motors, ground Hall 2 and only connect motor leads to Motor A and Motor B.

**HARDWARE SETTINGS**

**Jumper Settings**

The drive PCB is conformal coated, thereby making it difficult to change jumper settings. Jumpers are SMT 0 ohm resistors located on the underside of the drive PCB. By default, the drive is configured with the jumpers installed. Typical drive operation will not require the jumpers to be removed. Please contact the factory before jumper removal.

Jumper	Description	Configuration	
		Not Installed	Installed
	SMT Jumper (0 $\Omega$ Resistor)		
JE1	Inhibit logic. Sets the logic level of inhibit pins. Labeled JE1 on the PCB of the drive.	Low Enable	Low Inhibit
JE2	Hall sensor phasing. Selects 120 or 60 degree commutation phasing. Labeled JE2 on the PCB of the drive.	60 degree	120 degree

**MECHANICAL INFORMATION**

**P1 - Signal Connector**

Connector Information		16-pin, 2.54 mm spaced header
Mating Connector	Details	Samtec: BCS-116-L-S-PE
	Included with Drive	No

**P2 - Power Connector**

Connector Information		22-pin, 2.54 mm spaced, dual-row header
Mating Connector	Details	Samtec: SSM-111-L-DV
	Included with Drive	No



**PART NUMBERING INFORMATION**

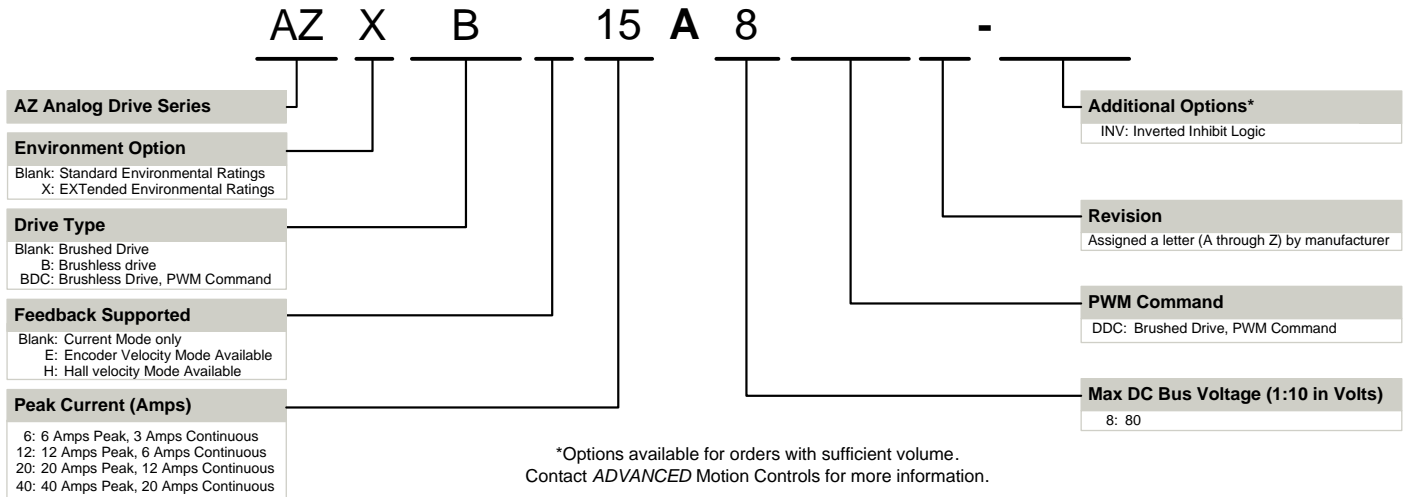

*ADVANCED* Motion Controls AZ series of servo drives are available in many configurations. All models listed in the selection tables of the website are readily available, standard product offerings.

*ADVANCED* Motion Controls also has the capability to promptly develop and deliver specified products for OEMs with volume requests. Our Applications and Engineering Departments will work closely with your design team through all stages of development in order to provide the best servo drive solution for your system. Equipped with on-site manufacturing for quick-turn customs capabilities, *ADVANCED* Motion Controls utilizes our years of engineering and manufacturing expertise to decrease your costs and time-to-market while increasing system quality and reliability.

**Examples of Modifications and Customized Products**

- ▲ Integration of Drive into Motor Housing
- ▲ Mount OEM PCB onto Drive Without Cables
- ▲ Multi-axis Configuration for Compact System
- ▲ Custom PCB and Baseplate for Optimized Footprint
- ▲ RTV/Epoxy Components for High Vibration
- ▲ OEM Specified Connectors for Instant Compatibility
- ▲ OEM Specified Silkscreen for Custom Appearance
- ▲ Increased Thermal Limits for High Temp. Operation
- ▲ Integrate OEM Circuitry onto Drive PCB
- ▲ Custom Control Loop Tuned to Motor Characteristics
- ▲ Custom I/O Interface for System Compatibility
- ▲ Preset Switches and Pots to Reduce User Setup
- ▲ Optimized Switching Frequency
- ▲ Ramped Velocity Command for Smooth Acceleration
- ▲ Remove Unused Features to Reduce OEM Cost
- ▲ Application Specific Current and Voltage Limits

Feel free to contact Applications Engineering for further information and details.

**Available Accessories**

*ADVANCED* Motion Controls offers a variety of accessories designed to facilitate drive integration into a servo system. Visit [www.a-m-c.com](http://www.a-m-c.com) to see which accessories will assist with your application design and implementation.

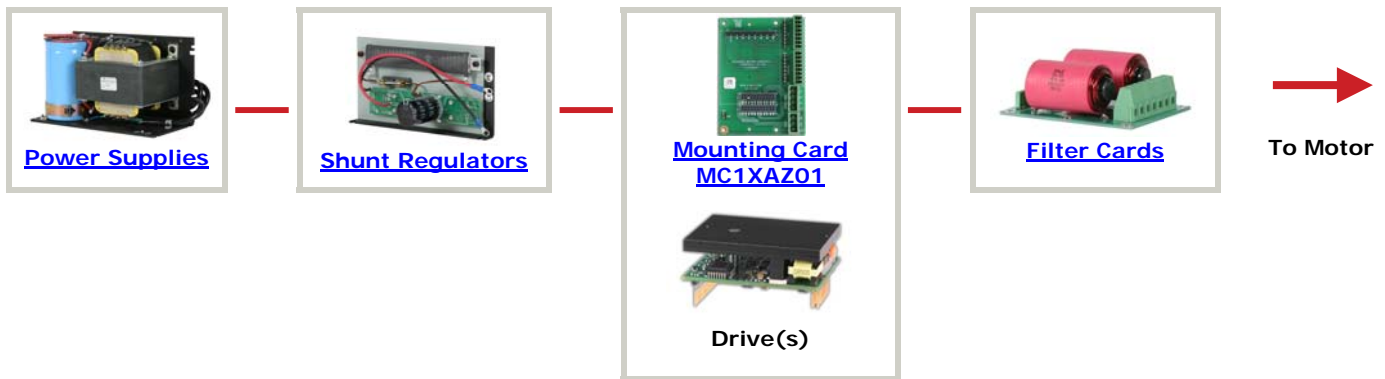

All specifications in this document are subject to change without written notice. Actual product may differ from pictures provided in this document.