

B15A SERIES BRUSHLESS SERVO AMPLIFIERS

Models: B12A6, B15A8, B15A20

FEATURES:

- Surface-mount technology
- Small size, low cost, ease of use
- DIP switch selectable: current, open loop, or tachometer velocity mode
- Four quadrant regenerative operation
- Agency Approvals:



BLOCK DIAGRAM

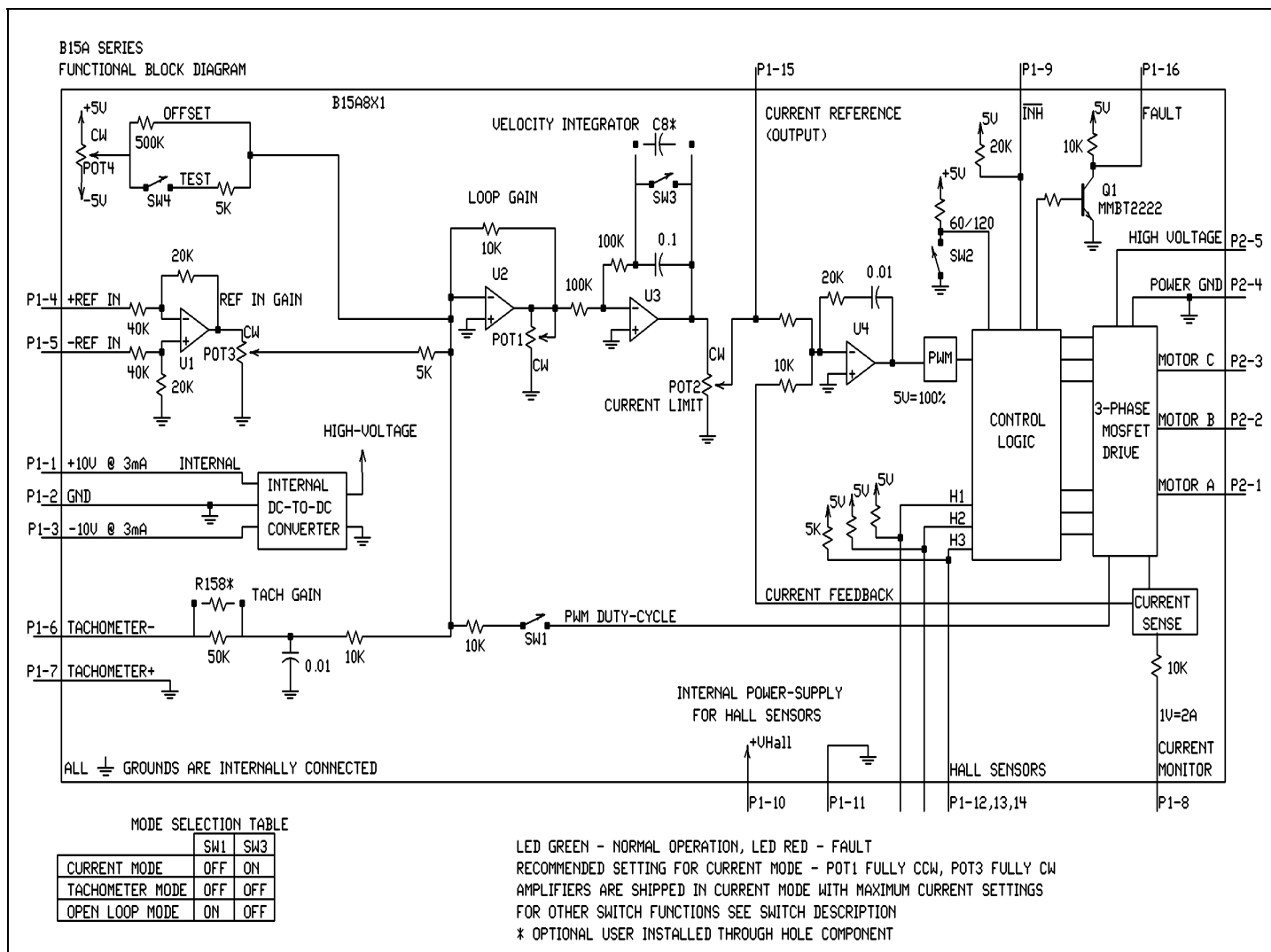

B15A Series

DESCRIPTION: The B15A Series PWM servo amplifiers are designed to drive brushless DC motors at a high switching frequency. A single red/green LED indicates operating status. B15A Series amplifiers are fully protected against over-voltage, over-current, over-heating and short-circuits. They interface with a digital controller or can be used as a stand-alone drive. This model requires only a single unregulated DC power supply. Loop gain, current limit, input gain and offset can be adjusted using 14-turn potentiometers. The offset adjusting potentiometer can also be used as an on-board input signal for testing purposes, when SW4 (DIP switch) is ON.

SPECIFICATIONS:

POWER STAGE SPECIFICATIONS	MODELS		
	B12A6	B15A8	B15A20*
DC SUPPLY VOLTAGE	20-60 V	20-80 V	40-190 V
PEAK CURRENT (2 sec. maximum)	± 12 A	± 15 A	± 15 A
MAXIMUM CONTINUOUS CURRENT	± 6 A	± 7.5 A	± 7.5 A
MINIMUM LOAD INDUCTANCE**	200 µH	200 µH	250 µH
SWITCHING FREQUENCY	33 kHz ± 15%		
HEATSINK (BASE) TEMPERATURE RANGE	-25° to + 65° C, disables if > 65° C		
POWER DISSIPATION AT CONTINUOUS CURRENT	18 W	30 W	75 W
OVER-VOLTAGE SHUT-DOWN (self reset)	62 V	86 V	195 V
BANDWIDTH (load dependent)	2.5 kHz	2.5 kHz	2.5 kHz

MECHANICAL SPECIFICATIONS	
POWER CONNECTOR	Screw terminals
SIGNAL CONNECTOR	Molex connector
SIZE	5.09 x 2.98 x 0.99 inches 129.3 x 75.8 x 25.1 mm
WEIGHT	10 oz. 0.28 kg

*Contact factory regarding CE rating.

** Low inductance motors require external inductors.

PIN FUNCTIONS:

CONNECTOR	PIN	NAME	DESCRIPTION / NOTES	I/O
P2	1	MOTOR A	Motor phase A connection	O
	2	MOTOR B	Motor phase B connection	O
	3	MOTOR C	Motor phase C connection	O
	4	POWER GND	Power ground	GND
	5	HIGH VOLTAGE	DC power input	I
P1	1	+10V @ 3 mA OUT	For customer use	O
	2	SIGNAL GND	Reference ground	GND
	3	-10V @ 3 mA OUT	For customer use	O
	4	+REF IN	Differential reference input, maximum ± 15 V, 40K input resistance	I
	5	-REF IN		
	6	-TACH IN	Tachometer input, max. ± 60 VDC, 60K input resistance	I
	7	+TACH / GND	Ground	GND
	8	CURRENT MONITOR OUT	Current monitor. 1 V = 2 A	O
	9	INHIBIT IN	This TTL level input signal turns off all power devices of the "H" bridge when pulled to ground. This inhibit will cause a fault condition and a red led. For inverted inhibit inputs, see section "G".	I
	10	+V HALL OUT	Power for HALL sensors, short circuit protected, +6 V @ +30 mA.	O
	11	GND		GND
	12	HALL 1	HALL sensor inputs, TTL logic levels, internal 5 K Ω pull-up. Maximum low level input is 1.5 V, minimum high level input is 3.5 V	I
	13	HALL 2		
	14	HALL 3		
	15	CURRENT REFERENCE OUT	Monitors the input signal connected directly to the internal current amplifier. 7.25 V = max current. See current limit adjustment information below.	O
	16	FAULT OUT (red LED)	TTL level output. Becomes high during output short circuit, over-voltage, inhibit, over-temperature and during power-on reset. Fault condition indicated by red LED.	O

SWITCH FUNCTIONS:

SWITCH	FUNCTION DESCRIPTION	SETTING	
		ON	OFF
1	Duty-cycle feedback	Open Loop	No Effect
2	60 / 120 degree commutation phasing setting	120 degree	60 degree
3	Loop integrator. This capacitor normally ensures "error-free" operation in velocity mode by reducing the error-signal (output of summing amplifier) to zero.	Shorts out the velocity / voltage loop integrator capacitor.	Velocity / voltage loop integrator capacitor operating.
4	Test / Offset. Sensitivity of the "offset" pot. Used as an on-board reference signal in test mode.	Test	Offset

POTENTIOMETER FUNCTIONS:

POTENTIOMETER	DESCRIPTION	TURNING CW
Pot 1	Loop gain adjustment in open loop & velocity modes.	Increases loop gain
Pot 2	Current limit. It adjusts both continuous and peak current limit while maintaining their ratio (50%).	Increases current limit
Pot 3	Reference gain. It adjusts the ratio between input signal and output variables (voltage, current, velocity).	Increases reference input gain
Pot 4	Test / Offset. Used to adjust any imbalance in the input signal or in the amplifier. When SW4 (DIP switch) is ON, the sensitivity of this pot is greatly increased thus it can be used as an on-board signal source for testing purposes. See section "G".	N/A

OPERATING MODE SELECTION:

These modes can be selected by the DIP switches according to the chart in the functional block diagram:

- Current mode
- Open loop mode
- Tachometer mode

See section "G" for more information.

SET-UP:

See section "G" for engineering and installation notes.

CURRENT LIMIT ADJUSTMENTS:

These amplifiers feature peak and continuous current limit adjustments. Potentiometer 2, the current limiting potentiometer, has 12 active turns plus 1 inactive turn at each end and is approximately linear. Thus, to adjust the current limit turn the potentiometer counter-clockwise to zero, then turn clockwise to the appropriate value.

P1-15 is the input to the internal current amplifier stage. Since the output current is proportional to P1-15, the adjusted current limit can easily be observed at this pin without connecting the motor. Note that a command signal must be applied to the reference inputs to obtain a reading on P1-15. The maximum peak current value equals 7.25 V at this pin and the maximum continuous current value equals 3.625 at this pin. Example: Using the B12A6, $7.25V=12A$.

The actual current can be monitored at pin P1-8.

TYPICAL SYSTEM WIRING: see section "G".

ORDERING INFORMATION:

Models: B12A6X, B15A8X, B15A20X

X indicates the current revision letter.

MOUNTING DIMENSIONS: See page F-7.