

B25A40AC SERIES BRUSHLESS SERVO AMPLIFIERS

Model: B25A40AC

1 \emptyset or 3 \emptyset VAC SUPPLY OPERATION



FEATURES:

- * Surface-mount technology
- * Small size, low cost, ease of use
- * Built in input signal isolation and shunt regulator
- * DIP switch selectable modes: current, open loop, analog tachometer, Hall velocity and encoder velocity
- * Four quadrant regenerative operation



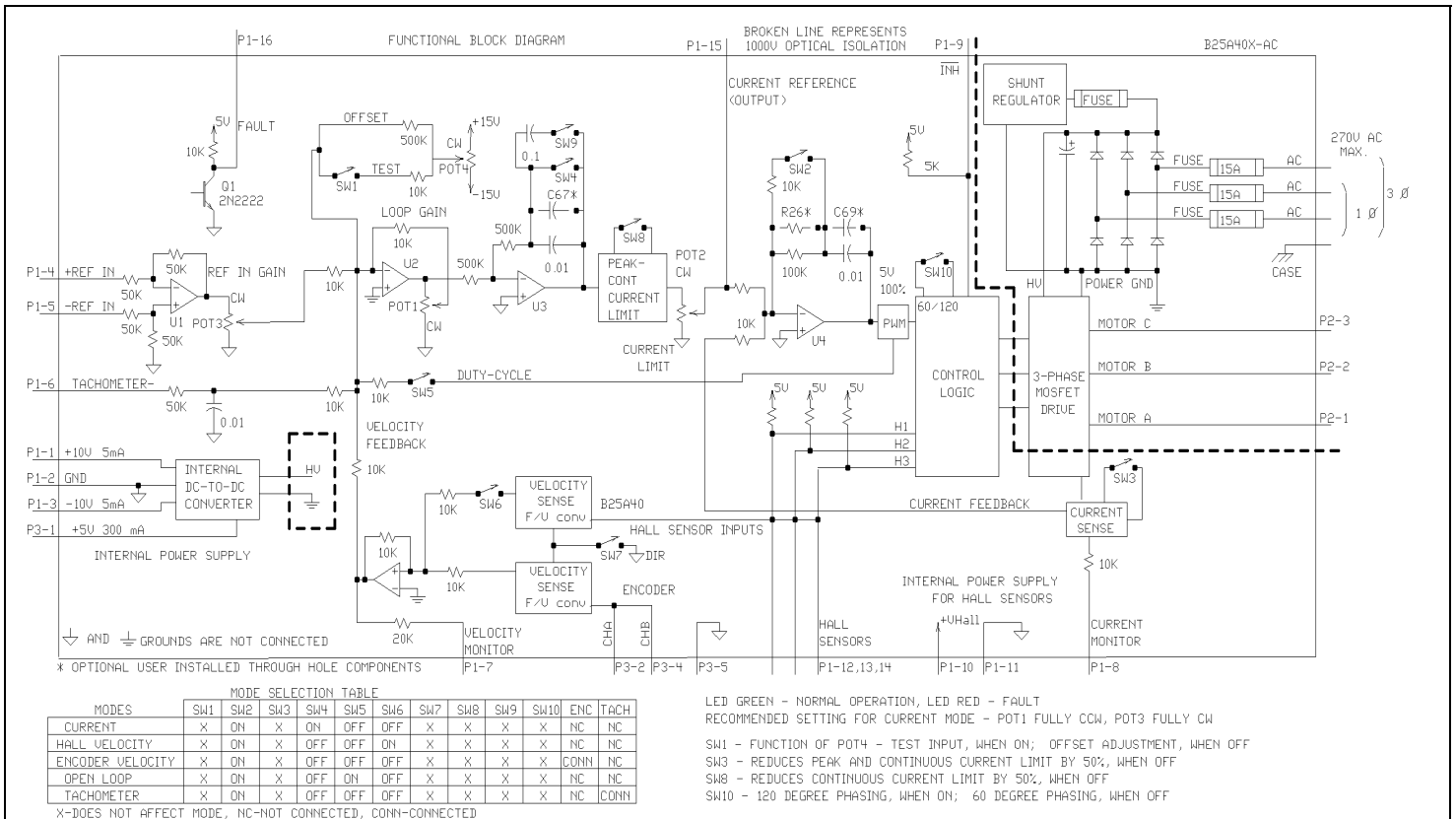

DESCRIPTION: B25A40AC Series PWM servo amplifiers are designed to drive brushless DC motors at a high switching frequency. This model is fully protected against over-voltage, under-voltage, over-current, over-heating and short-circuits. This model interfaces with a digital controller or can be used as stand-alone drive. The B25A40AC requires only a 1Ø or 3Ø AC power supply. A single red/green LED and a single digital output indicate operating status. Loop gain, current limit, input gain and offset can be adjusted using 14-turn potentiometers. The offset adjusting potentiometer can also be used as an on-board input signal for testing purposes when SW1 (DIP switch) is ON.

ADVANCED MOTION CONTROLS

3629 Vista Mercado, Camarillo, CA 93012 Tel: (805) 389-1935, Fax: (805) 389-1165

All B25A40AC specifications are identical to the B25A40 specifications (see page C-34) except for:

	MODEL
POWER STAGE SPECIFICATIONS	B25A40AC
AC SUPPLY VOLTAGE	85-270 VAC @ 50 - 60 Hz
SHUNT SWITCH-ON VOLTAGE*	390 VDC
SHUNT RESISTOR	20 Ω @ 100 W
SHUNT FUSE (d=.25 inches, L=1.25 inches)	3 A Motor Delay rated @ 250 VAC
AC LINE FUSES (d=.25 inches, L=1.25 inches)	15 A slow-blow rated @ 250 VAC

MECHANICAL SPECIFICATIONS	
POWER CONNECTOR	Screw terminals
SIGNAL CONNECTOR	Molex connector
SIZE	x 6.35 x 3.43 inches 203.2 x 161.3 x 87.2 mm
WEIGHT	lb. 2.18 kg

* If the shunt regulator is disabled the shut down voltage is 420 VDC.

These amplifiers contain a rectifier bridge and filter capacitors to generate the DC bus internally from the AC input power. The DC bus voltage is 1.4 times AC voltage (RMS), e.g. 310 VDC from 220 VAC. During braking much of the stored mechanical energy is fed back into the power supply and charges the output capacitor to a higher voltage. If the charge reaches the amplifier's over-voltage shutdown point, output current and braking will cease. To ensure smooth braking of large inertial loads, a built-in "shunt regulator" is provided in the B25A40AC. The shunt regulator will switch-on the internal power resistor when the bus voltage reaches 390 VDC. This resistor then dissipates the extra energy of the DC bus to the case. If the temperature of the case rises above 65 °C, a thermal switch will disable the shunt regulator. As a result, the amplifier will operate without the shunt regulator and the over voltage protection on the amplifier will disable the drive if the regeneration energy causes the bus voltage to exceed 420 VDC.

ORDERING INFORMATION

Models: B25A40ACX

X indicates the current revision letter.

TYPICAL SYSTEM WIRING: See section "G".

MOUNTING DIMENSIONS:

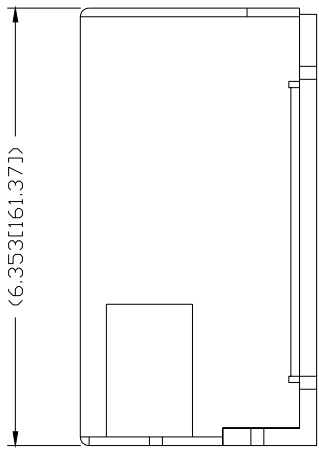
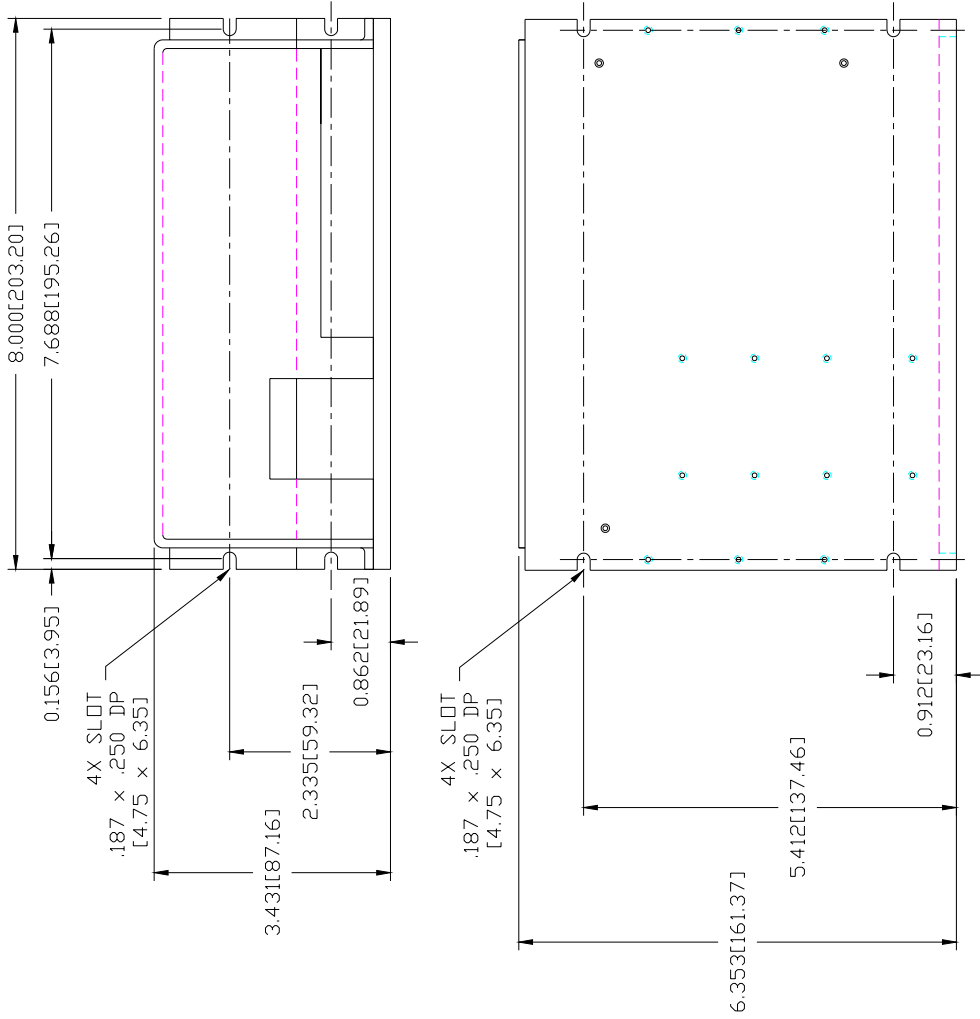

A	UPDATE DWG. FORMAT	11/04/96	RB
REV	DESCRIPTION	DATE	BY
ADVANCED MOTION CONTROLS • PWM SERVO AMPLIFIERS 3629 Vista Merced, Menlo Park, CA 94025			
UNLESS OTHERWISE SPECIFIED: DIMENSIONS ARE IN INCHES TOLERANCES .XX ± .010 .XXX ± .005 DO NOT SCALE DRAWING		TITLE MOUNTING DIMENSIONS MB25A40AC	
DRAWN BY: R. BAUTISTA		DATE: 09/06/95	
CHECK BY:		DATE:	
DESIGN APPROVED:		DATE:	
B25A40AC SERIES USED ON		SIZE DWG. NO C MDB25AAC	
		SCALE: NONE	
		SHT. 1 OF 1	

NOTE: DIMENSION IN [] ARE IN MM.