

BE30A SERIES BRUSHLESS SERVO AMPLIFIERS

Models: BE25A20I, BE40A20I

FEATURES:

- Surface-mount technology
- Small size, low cost, ease of use
- Optional input signal isolation
- DIP switch selectable modes: current, open loop, tachometer, or encoder velocity
- Four quadrant, regenerative operation
- Hall sensor commutation
- Agency Approvals:

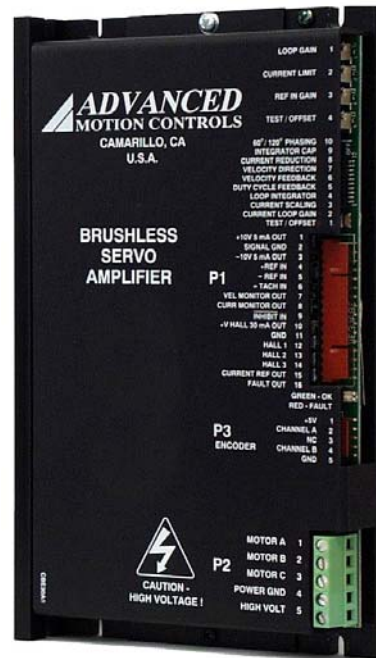

BLOCK DIAGRAM:

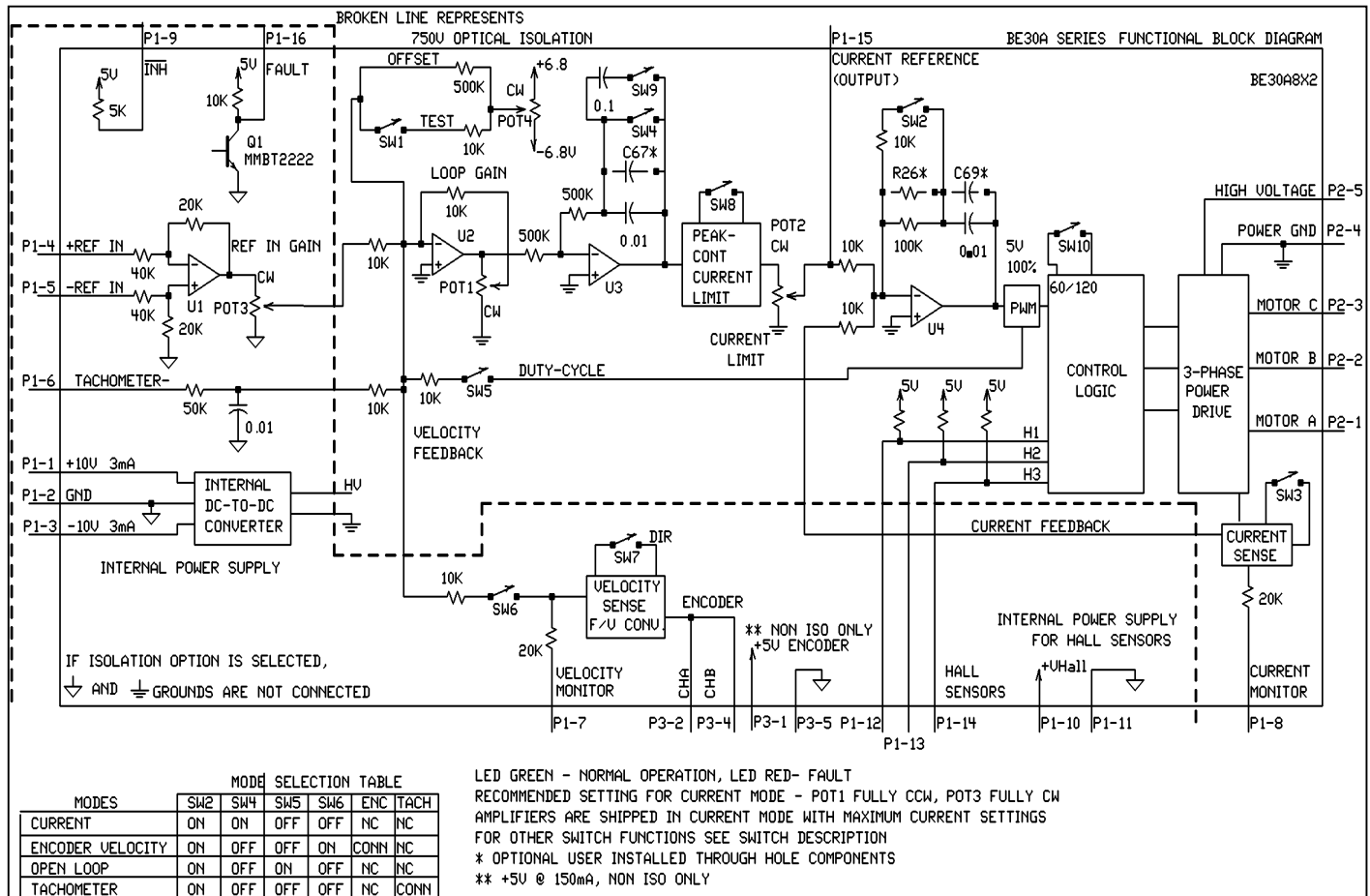

DESCRIPTION: The BE30A Series PWM servo amplifiers are designed to drive brushless DC motors at a high switching frequency. They are fully protected against over-voltage, over-current, over-heating and short-circuits. All models interface with digital controllers or can be used as stand-alone drives. They require only a single unregulated DC power supply. A single red/green LED indicates operating status. Loop gain, current limit, input gain and offset can be adjusted using 14-turn potentiometers. The offset adjusting potentiometer can also be used as an on-board input signal for testing purposes when SW1 (DIP switch) is ON. These models can use quadrature encoder inputs for velocity control.

SPECIFICATIONS:

POWER STAGE SPECIFICATIONS	MODELS		
		BE25A20I	BE40A20I
DC SUPPLY VOLTAGE		40 - 190 V	40 – 190 V
PEAK CURRENT (2 sec. max., internally limited)		± 25 A	± 40 A
MAX. CONTINUOUS CURRENT (internally limited)		± 12.5 A	± 20 A
MINIMUM LOAD INDUCTANCE*		250 µH	250 µH
SWITCHING FREQUENCY	22 kHz ± 15%		
HEATSINK (BASE) TEMPERATURE RANGE	0° to +65° C, disables if > 65° C		
POWER DISSIPATION AT CONTINUOUS CURRENT		125 W	200 W
OVER-VOLTAGE SHUT-DOWN (self reset)		195 V	195 V
BANDWIDTH (load dependent)	2.5 kHz		

MECHANICAL SPECIFICATIONS	
POWER CONNECTOR	Screw terminals
SIGNAL CONNECTOR	Molex connector
SIZE	7.35 x 4.40 x 1.00 inches
	186.7 x 111.7 x 25.4 mm
WEIGHT	1.5 lb.
	0.68 kg

* Low inductance motors require external inductors.

PIN FUNCTIONS:

CONNECTOR	PIN	NAME	DESCRIPTION / NOTES	I/O
P1	1	+10V 3 mA OUT	For customer use	O
	2	SIGNAL GND	Reference ground	SGND
	3	-10V 3 mA OUT	For customer use	O
	4	+REF IN	Differential reference input, Maximum ± 15 V, 40K input resistance	I
	5	-REF IN		
	6	-TACH IN	Tachometer input, max. ± 60 VDC, 60K input resistance	I
	7	VELOCITY MONITOR OUT	Velocity monitor, 1 V = 22 kHz encoder frequency	O
	8	CURRENT MONITOR OUT	Model BE25A20I: when SW3 is OFF, 1 V = 2 A; when SW3 is ON, 1 V = 4 A. Model BE40A20I: when SW3 is OFF, 1 V = 4 A; when SW3 is ON, 1 V = 8 A	O
	9	INHIBIT IN	This TTL level input signal turns off all power devices of the "H" bridge when pulled to ground. This inhibit will cause a fault condition and a red led. For inverted inhibit inputs, see section "G".	I
	10	+V HALL 30 mA OUT	Power for HALL sensors, short circuit protected, +6 V @ +30 mA	O
	11	GND		SGND
	12	HALL 1	HALL sensor inputs, logic levels, Internal 5 K Ω pull-up. Maximum low level input is 1.5 V, minimum high level input is 3.5 V	I
	13	HALL 2		
	14	HALL 3		
	15	CURRENT REFERENCE OUT	Monitors the input signal connected directly to the internal current amplifier. 7.25 V = max peak current. See current limit adjustment information below.	O
	16	FAULT OUT (LED red)	Transistor output. Becomes high during output short circuit, over-voltage, over temperature, inhibit, and power-up reset. Fault condition indicated by red LED.	O
P2	1	MOTOR A	Motor phase A connection	O
	2	MOTOR B	Motor phase B connection	O
	3	MOTOR C	Motor phase C connection	O
	4	POWER GND	Power ground	PGND
	5	HIGH VOLT	DC power input	I
P3 ENCODER	1	RESERVED	Reserved.	O
	2	CHANNEL A	5V CMOS level quadrature encoder input	I
	3	NC	Not connected	
	4	CHANNEL B	5V CMOS level quadrature encoder input	I
	5	SIGNAL GND	Reference gnd for encoder	SGND

SWITCH FUNCTIONS:

SWITCH	FUNCTION DESCRIPTION	SETTING	
		ON	OFF
1	Test / Offset. Sensitivity of the "offset" pot. Used as an on-board reference signal in test mode.	Test	Offset
2	Current loop gain	Decrease	Increase
3	Current scaling. When OFF, increases sensitivity of current sense thus reducing both peak and continuous current limit by 50%.	100%	50%
4	Loop integrator. This capacitor normally ensures "error-free" operation in velocity mode by reducing the error signal (output of summing amplifier) to zero.	Shorts out the velocity/voltage loop integrator capacitor	Velocity/voltage loop integrator operating
5	Internal duty-cycle feedback for open loop mode	On	Off
6	Velocity feedback. Connects the internally generated velocity signal from encoder.	On	Off
7	Velocity direction. Changes the polarity of the velocity monitor signal.		
8	Continuous current reduction. Reduces continuous current limit by 50%.	Continuous / peak current limit ratio is 50%	Continuous / peak current limit ratio is 25%
9	Integrator capacitor. Adjusts the value of the integrator capacitor in velocity mode.	Increase	Decrease
10	60/120 degree commutation phasing setting	120 degree phasing	60 degree phasing

POTENTIOMETER FUNCTIONS:

POTENTIOMETER	DESCRIPTION	TURNING CW
Pot 1	Loop gain adjustment in open loop & velocity modes. Turn this pot fully ccw in current mode.	Increases loop gain
Pot 2	Current limit. It adjusts both continuous and peak current limit maintaining selected ratio (50%).	Increases current limit
Pot 3	Reference gain. It adjusts the ratio between input signal and output variables (voltage, current, velocity).	Increases reference input gain
Pot 4	Test / Offset. Used to adjust any imbalance in the input signal or in the amplifier. When SW1 (DIP switch) is ON, the sensitivity of this pot is greatly increased thus it can be used as an on-board signal source for testing purposes. See section "G".	N/A

TEST POINTS FOR POTENTIOMETERS: See section "G".

OPERATING MODE SELECTION:

These modes can be selected by the DIP switches according to the chart in the functional block diagram:

- Current mode
- Open loop mode
- Tachometer mode
- Encoder velocity mode

See section "G" for more information.

SET-UP: See section "G" for engineering and installation notes.

CURRENT LIMIT ADJUSTMENTS:

These amplifiers feature separate peak and continuous current limit adjustments. The current limit adjustment Pot 2 adjusts both peak and continuous current limit simultaneously. It has 12 active turns plus 1 inactive turn at each end and is approximately linear. Thus, to adjust the current limit turn the potentiometer fully counter-clockwise, then turn clockwise to the appropriate value.

In many applications it is sufficient to use only the DIP switches for current limit adjustments. SW3 reduces both peak and continuous current limit by 50% when OFF. SW8 reduces only the continuous current limit by 50% when OFF:

SW8	CONTINUOUS / PEAK CURRENT LIMIT RATIO
ON	50%
OFF	25%

P1-15 is the input to the internal current amplifier power stage. Since the output current is proportional to P1-15, the adjusted current limit can easily be observed at this pin without connecting the motor. Note that a command signal must be applied to the reference inputs to obtain a reading on P1-15. The maximum peak current value equals 7.25 V at this pin and the maximum continuous current value equals 3.63 V at this pin. If SW3=ON, peak rated amplifier current = 7.25 V. If SW3=OFF, $\frac{1}{2}$ peak rated amplifier current = 7.25 V.

The actual current can be monitored at pin P1-8.

OPTIONAL INPUT SIGNAL ISOLATION:

750 V optical input signal isolation is present for the BE25A20I and BE40A20I. All input and output signals are isolated from the power stage except CURR MONITOR (P1-8) and CURRENT REF (P1-15). They are referenced to POWER GND (P2-4).

B100A-AC Series

ORDERING INFORMATION:

Models: BE25A20IX, BE40A20IX

X indicates the current revision letter.

TYPICAL SYSTEM WIRING: See section "G".

MOUNTING DIMENSIONS: See page F-9.