

Power Supplies

	Model Number	DC Output Voltage	Output Current	Output Power	Isolation
120 VAC Single Phase Input	PS300W24	24 VDC	12 A	300 W	YES
	PS300W48	48 VDC	6 A	300 W	YES
	PS300W72	72 VDC	3 A	220 W	YES
	PS300W96	96 VDC	3 A	300 W	YES
	PS300W170	170 VDC	15 A	2550 W	NO
240 VAC Single Phase Input	PS300H24	24 VDC	12 A	300 W	YES
	PS300H48	48 VDC	6 A	300 W	YES
	PS300H72	72 VDC	3 A	220 W	YES
	PS300H96	96 VDC	3 A	300 W	YES



PS300x24,48,72,96



PS300W170

Note: AC Power cord included with 120 VAC input models only

Description

The PS300 unregulated power supplies have been designed to complement **ADVANCED Motion Controls'** servo drives and to provide the user with a complete solution to single and multi-axis DC drive applications. These unregulated DC power sources are an excellent solution for most applications as **ADVANCED** Motion Controls' servo drives compensate for power supply output variations and AC ripple components.

PS300 Series power supplies are designed to provide the best cost-per-watt value. They have multiple primary windings for either 120 VAC (PS300W) or 240 VAC (PS300H) 50/60 Hz operation. These power supplies feature four identical secondary windings that can be connected in series or in parallel for different output voltages and currents.

Features

- ▲ Multiple Primary Windings: Either 120 VAC or 240 VAC, 50/60 Hz Operation
- ▲ 24 VDC Secondary Output Winding Taps
- ▲ Small Size, Low Cost, Ease of Use
- ▲ Isolation Transformer on All Power Supply Models Except PS300W170
- ▲ Slow Blow Fuse on AC Input

Approvals and Compliances

	Compliant with European CE for both the Class A EMC Directive 2004/108/EC on Electromagnetic Compatibility (specifically EN 61000-6-4:2007 and EN 61000-6-2:2005) and LVD requirements of directive 2006/95/EC (specifically EN 60204-1:2006), a low voltage directive to protect users from electrical shock.
	RoHS (Reduction of Hazardous Substances) is intended to prevent hazardous substances such as lead from being manufactured in electrical and electronic equipment.

SPECIFICATIONS

Power Specifications (120 VAC Single Phase Power Supplies)						
Description	Units	PS300W24	PS300W48	PS300W72	PS300W96	PS300W170
AC Supply Voltage Input	VAC	120				
AC Supply Input Frequency	Hz	50-60 Hz				
AC Supply Input Phases	-	Single Phase				
Output Voltage	VDC	24	48	72	96	170
Current Output	A	12	6	3	3	15

Power Specifications (240 VAC Single Phase Power Supplies)						
Description	Units	PS300H24	PS300H48	PS300H72	PS300H96	
AC Supply Voltage Input	VAC	240				
AC Supply Input Frequency	Hz	50-60 Hz				
AC Supply Input Phases	-	Single Phase				
Output Voltage	VDC	24	48	72	96	
Current Output	A	12	6	3	3	

Mechanical Specifications		
Description	Units	PS300 Series
AC Input Connector ¹	-	AC Power Cord
DC Output Connector	-	Flying Leads
Size (H x W x D) ²	mm (in)	218.44 x 102.87 x 139.70 (8.60 x 4.05 x 5.50)
Weight	kg (lbs)	4.53 (10)

Notes

1. Power cord not included with 240 VAC input models.
2. Worst case depth dimension. Height varies with model number. See mounting dimensions for additional details.

BLOCK DIAGRAMS

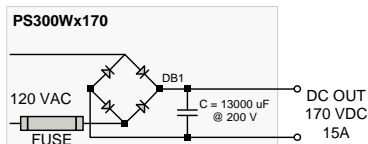
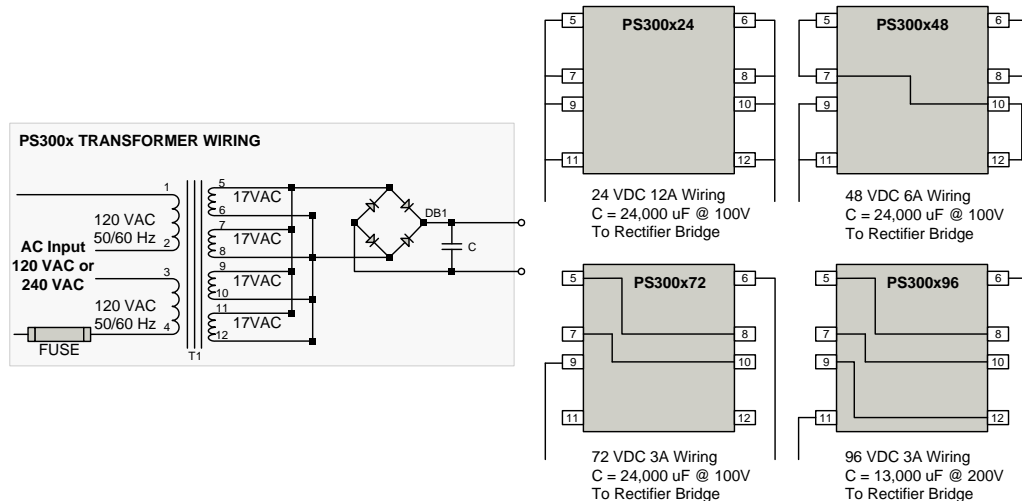
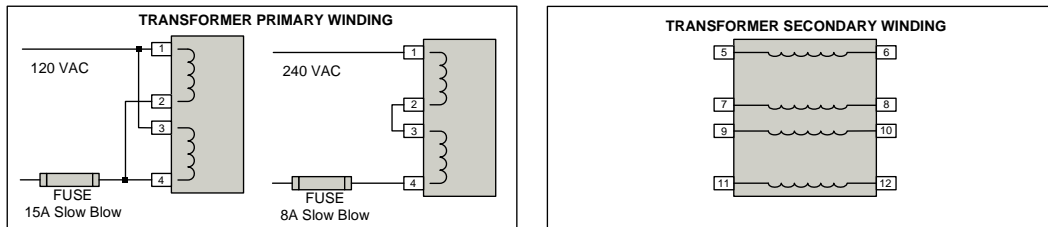

MOUNTING DIMENSIONS

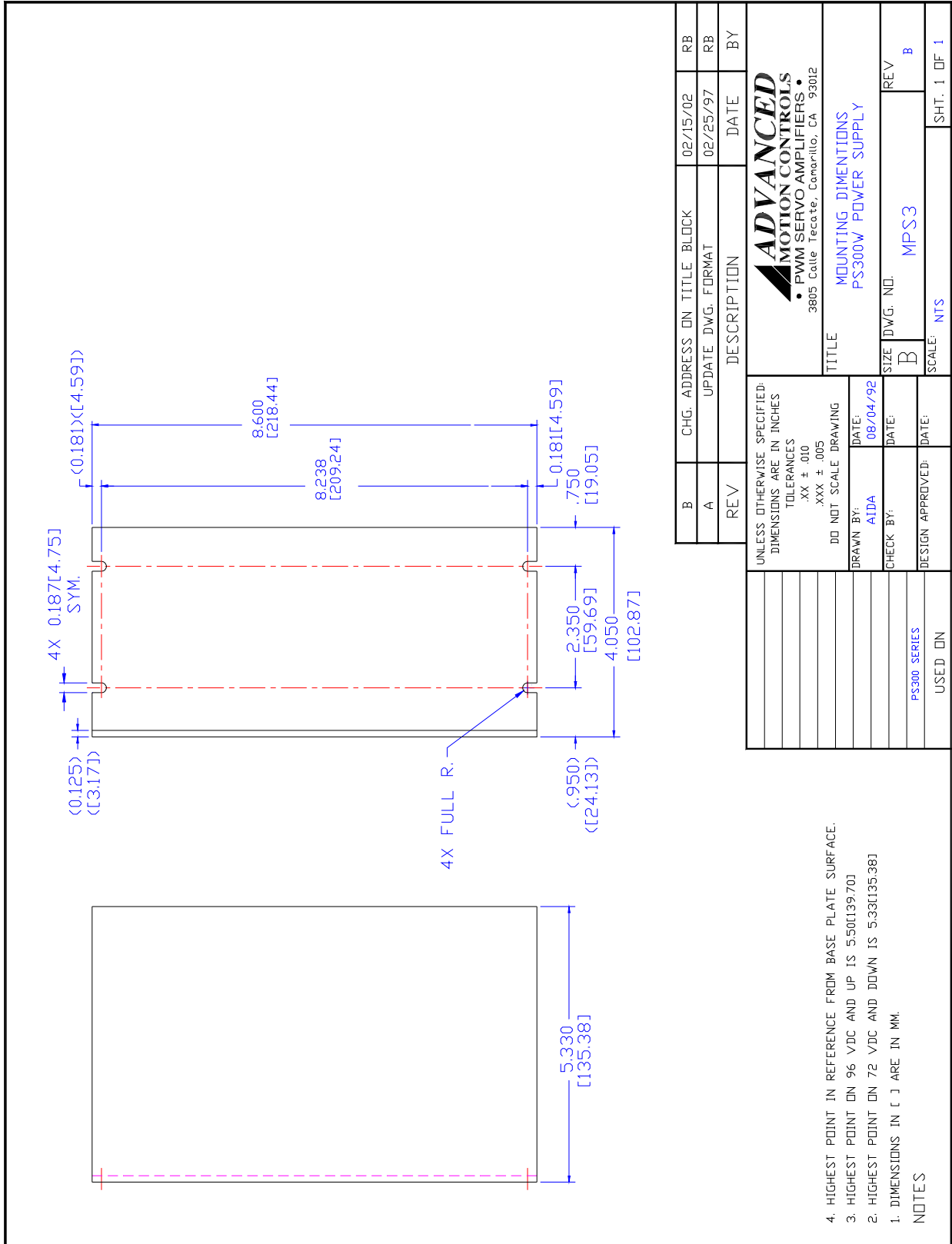

CUSTOMIZATION INFORMATION

ADVANCED Motion Controls' products are available in many configurations. All models listed in the selection tables of the website are readily available, standard product offerings.

ADVANCED Motion Controls also has the capability to promptly develop and deliver specified products for OEMs with volume requests. Our Applications and Engineering Departments will work closely with your design team through all stages of development in order to provide the best servo drive solution for your system. Equipped with on-site manufacturing for quick-turn customs capabilities, ADVANCED Motion Controls utilizes our years of engineering and manufacturing expertise to decrease your costs and time-to-market while increasing system quality and reliability. Feel free to contact Applications Engineering for further information and details.

Examples of Customized Products

- ▲ Optimized Footprint
- ▲ Private Label Software
- ▲ OEM Specified Connectors
- ▲ No Outer Case
- ▲ Increased Current Resolution
- ▲ Increased Temperature Range
- ▲ Custom Control Interface
- ▲ Integrated System I/O
- ▲ Tailored Project File
- ▲ Silkscreen Branding
- ▲ Optimized Base Plate
- ▲ Increased Current Limits
- ▲ Increased Voltage Range
- ▲ Conformal Coating
- ▲ Multi-Axis Configurations
- ▲ Reduced Profile Size and Weight

Available Accessories

ADVANCED Motion Controls offers a variety of accessories designed to facilitate drive integration into a servo system. Visit www.a-m-c.com to see which accessories will assist with your application design and implementation.



All specifications in this document are subject to change without written notice. Actual product may differ from pictures provided in this document.