

S30A SERIES THREE PHASE SINUSOIDAL BRUSHLESS SERVO AMPLIFIERS

Model: S30A8, S25A20

FEATURES:

- Surface-mount technology
- Small size, low cost, ease of use
- Sinusoidal drive and current control
- Optical isolation, see block diagram
- Four quadrant regenerative operation
- Agency approval pending

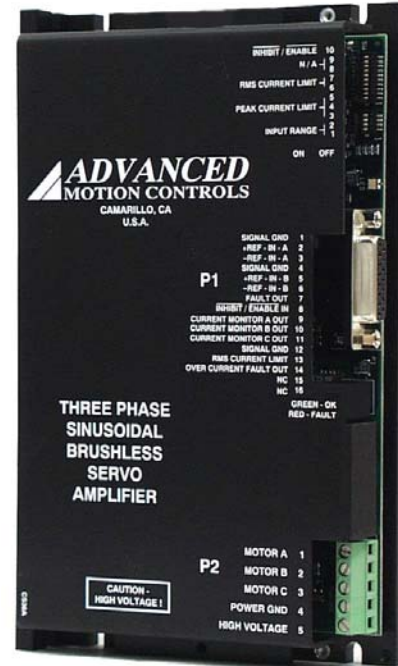

BLOCK DIAGRAM:

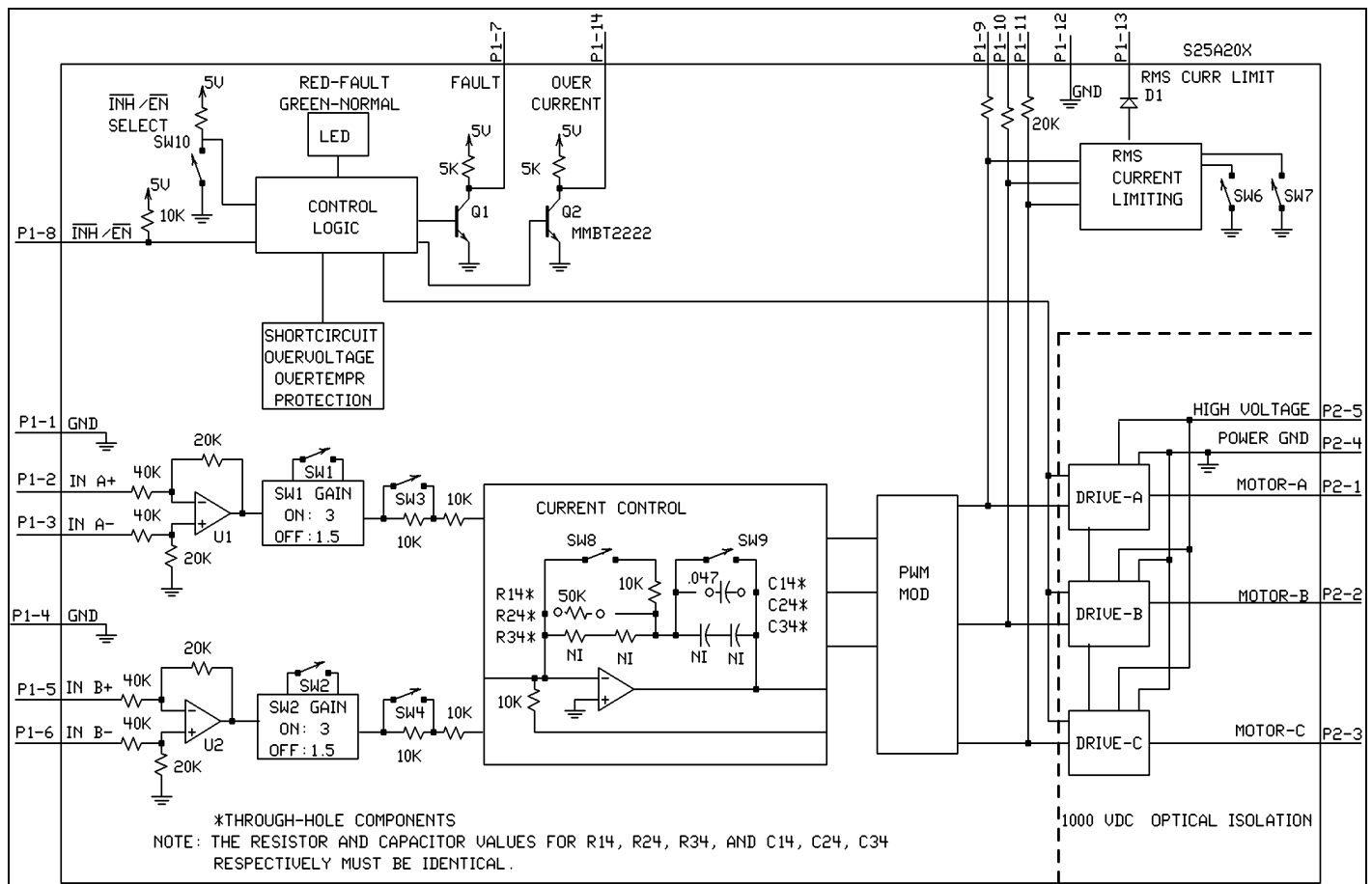

ADVANCED MOTION CONTROLS
3629 Vista Mercado, Camarillo, CA 93012

Tel: (805) 389-1935, Fax: (805) 389-1165

S30A Series

DESCRIPTION: S30A Series PWM servo amplifiers are designed to drive three phase brushless motors with sine wave current at a high switching frequency. They require two sinusoidal command signals with a 120-degree phase shift (external commutation). The phase angle must correspond to the position of the motor rotor, while the signal amplitude controls the motor torque. All models typically interface directly with digital controllers. The amplifiers are fully protected against over-voltage, under-voltage, over-current, over-heating, and short-circuits. The S30A series amplifiers require only a single unregulated DC power supply (all logic and control voltages are generated internally). A red/green LED and two digital outputs indicate operating status.

SPECIFICATIONS:

POWER STAGE SPECIFICATIONS	MODEL	
	S30A8	S25A20
DC SUPPLY VOLTAGE	25 – 80 V	25 – 190 V
PEAK CURRENT (2 sec. max., internally limited)	± 30 A (21.2 Arms)	± 25 A (17.7 Arms)
MAXIMUM CONTINUOUS CURRENT (internally limited)	± 15 A (10.6 Arms)	± 12.5 A (8.8 Arms)
MINIMUM LOAD INDUCTANCE*	200 µH	250 µH
SWITCHING FREQUENCY	22 kHz nominal	
HEATSINK (BASE) TEMPERATURE RANGE	-25° to +65° C, disables if >65° C	
POWER DISSIPATION AT CONTINUOUS CURRENT	60 W	120 W
OVER-VOLTAGE SHUT-DOWN (self-reset)	196 V	196 V
BANDWIDTH (load dependent)	2.5 kHz	

MECHANICAL SPECIFICATIONS	
POWER CONNECTOR: P2	Screw Terminals
SIGNAL CONNECTOR: P1	15 pin D-Sub
SIZE	7.35 x 4.40 x 1.54 inches 186.7 x 111.8 x 39.2 mm
WEIGHT	1.5 lb. 0.68 Kg

* Low inductance motors require external inductors.

PIN FUNCTIONS

CONNECTOR	PIN	NAME	DESCRIPTION / NOTES	I/O
P2	1	MOTOR A	Motor phase A connection	O
	2	MOTOR B	Motor phase B connection	O
	3	MOTOR C	Motor phase C connection	O
	4	POWER GND	Power ground	GND
	5	HIGH VOLTAGE	DC power input	I
P1/P3	1	SIGNAL GND	Signal ground	GND
	2	+REF-IN-A	Differential reference input, maximum ± 15 V, 40K input resistance	I
	3	-REF-IN-A		
	4	SIGNAL GND	Signal ground	GND
	5	+REF-IN-B	Differential reference input, maximum ± 15 V, 40K input resistance	I
	6	-REF-IN-B		
	7	FAULT OUT	This transistor output becomes high during short circuit, over-voltage, under voltage, and power-on reset. A red LED also indicates a fault condition.	O
	8	INHIBIT / ENABLE	This TTL level input signal turns off all power devices of the "H" bridge when pulled to ground with SW10=ON. If SW10 = OFF pulling this pin to ground will enable the amplifier. This inhibit will cause a fault condition and a red led. For inverted inhibit inputs, see section "G".	I
	9	CURRENT MONITOR A	Phase current monitor; 7.2 V = maximum peak current setting.	O
	10	CURRENT MONITOR B		
	11	CURRENT MONITOR C		
	12	SIGNAL GROUND	Signal ground	GND
	13	RMS CURRENT LIMIT	The RMS current limit can be controlled by an external voltage; 5 V = maximum RMS current limit. This is referenced to P1-1. No input to this pin is necessary to obtain maximum current.	O
	14	OVER-CURRENT	This transistor output becomes high if RMS current (in any phase) exceeds RMS current limit.	O
	15	NC	Reserved	

SWITCH FUNCTIONS

SWITCH	FUNCTION DESCRIPTION	SETTING	
		ON	OFF
1	Input Range Selection*	Input range ± 5 V ± 5 V = Max. current when SW1, 2 = ON	Input range ± 10 V ± 10 V = Max. current when SW1, 2 = OFF
2			
3	Peak Current Limit**	The peak current limit equals 100% of the maximum peak current when SW3 and SW4 are ON.	The peak current limit equals 50% of the maximum peak current when SW3 and SW4 are OFF.
4			
5	Reserved		
6	RMS Current Limit	See Table 1 below.	
7			
8	Current Loop Gain***	Decrease	Increase
9	Current Loop Integrator***	Recommended setting is OFF.	
10	INHIBIT/ENABLE	P1-8 : INHIBIT	P1-8 : ENABLE

* Switches 1 and 2 must be set the same

** Switches 3 and 4 must be set the same

*** See item "6.3 Current Loop Adjustments" in section G for more information

TABLE 1

SW6	SW7	PERCENTAGE OF MAXIMUM CONTINUOUS CURRENT
ON	ON	100%
OFF	ON	100%
ON	OFF	50%
OFF	OFF	25%

CURRENT LIMIT

Current limiting for each motor winding is independent. The peak current is maintained for two seconds. If the RMS value of the winding current exceeds the RMS current limit the amplifier shuts off. The shut off condition is indicated by high OVER CURRENT, high FAULT signal, and red LED. The amplifier will re-enable when the RMS current returns to values within the RMS current limit range.

ORDERING INFORMATION

Model: S25A20X

X indicates the current revision letter.

TYPICAL SYSTEM WIRING: See section "G".

MOUNTING DIMENSIONS: See page F-10.

