

SE30A SERIES BRUSHLESS SERVO AMPLIFIERS

Models: SE10A8, SE10A20, SE10A40, SE30A8, SE30A20, SE30A40

FEATURES:

- Surface-mount technology
- Small size, low cost, ease of use
- Optical isolation, see block diagram
- DIP switch selectable modes: current, encoder velocity, external velocity, tachometer
- Four quadrant regenerative operation
- Encoder interface for sinusoidal commutation
- Agency Approvals:



BLOCK DIAGRAM:

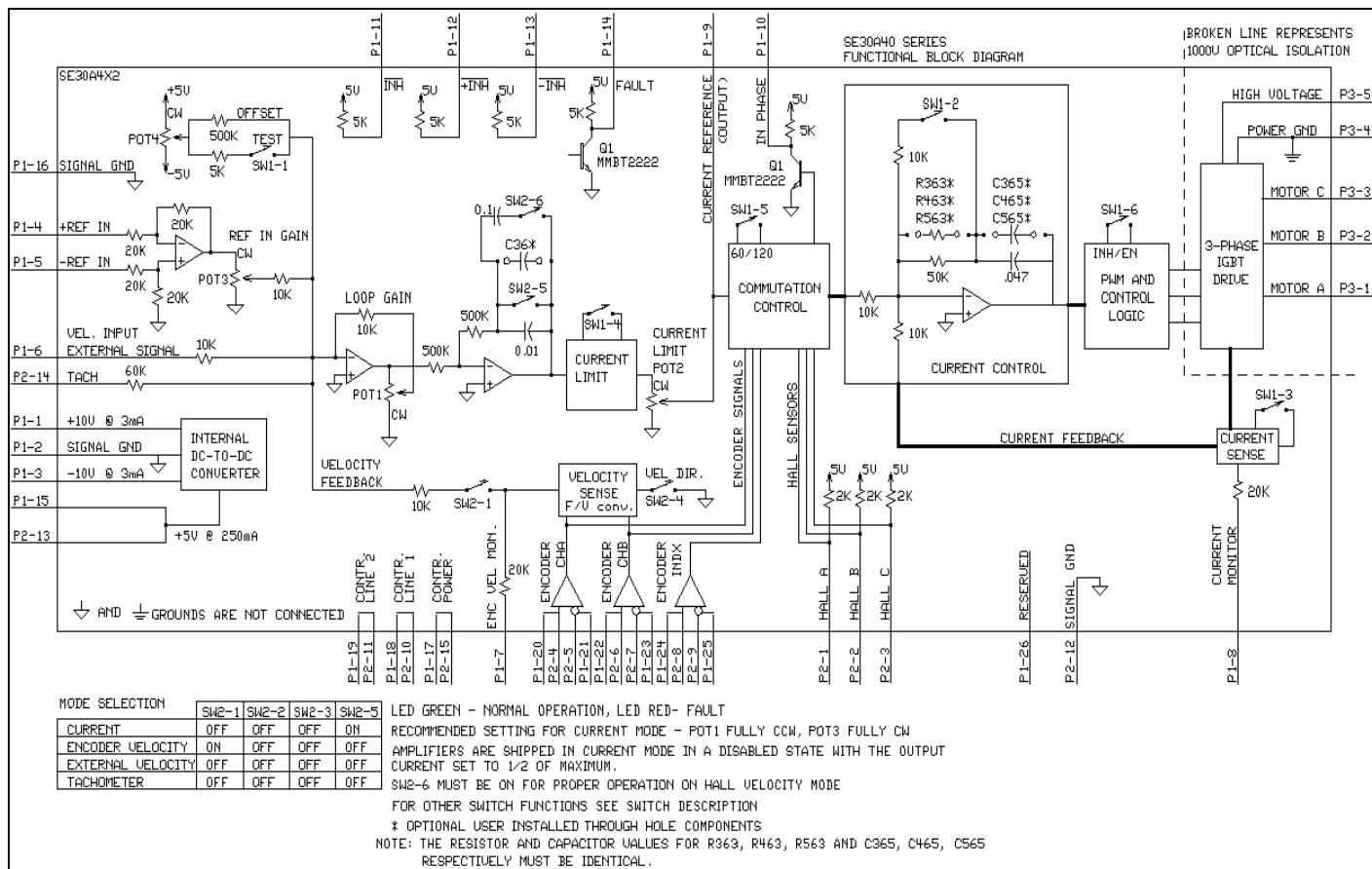

DESCRIPTION: The SE30A20 Series PWM servo amplifiers are designed to drive brushless motors with 3 phase sine wave current. An on board digital controller generates the 3 phase sine wave signals from an optical "incremental encoder". Although encoders are used for the sinusoidal commutation, Hall sensors are required for the start up routine. This model is fully protected against over-voltage, under-voltage, over-current, over-heating and short-circuits. This model interfaces with digital controllers or can be used as a stand-alone drive. The SE30A20 series amplifiers require only a single unregulated DC power supply. A red/green LED and two digital outputs indicate operating status. Loop gain, current limit, input gain and offset can be adjusted using 14-turn potentiometers. The offset adjusting potentiometer can also be used as an on-board input signal for testing purposes when SW1 (DIP switch) is ON.

SPECIFICATIONS:

POWER STAGE SPECIFICATIONS	MODEL					
	SE10A8*	SE10A20*	SE10A40	SE30A8*	SE30A20*	SE30A40
DC SUPPLY VOLTAGE	20-80 V	60-190 V	60-400 V	20-80 V	60-190 V	60-400 V
PEAK CURRENT (2 sec. Max., internally limited)	±10 A (7.1 Arms)	±10 A (7.1 Arms)	±10 A (7.1 Arms)	±30 A (21.2 Arms)	±30 A (21.2 Arms)	±30 A (21.2 Arms)
MAXIMUM CONTINUOUS CURRENT (internally limited)	±5 A (3.5 Arms)	±5 A (3.5 Arms)	±5 A (3.5 Arms)	±15 A (10.6 Arms)	±15 A (10.6 Arms)	±15 A (10.6 Arms)
MINIMUM LOAD INDUCTANCE *	200 µH	250 µH	600 µH	200 µH	250 µH	600 µH
SWITCHING FREQUENCY	20 kHz nominal					
HEATSINK (BASE) TEMPERATURE RANGE	0° to +65°C, disables if > 65°C					
POWER DISSIPATION AT CONT. CURRENT	20 W	50 W	100 W	60 W	145 W	300 W
OVER-VOLTAGE SHUT-DOWN (self reset)	84 V	195 V	425 V	84 V	195 V	425 V
BANDWIDTH (load dependent)	2.5 kHz					

MECHANICAL SPECIFICATIONS	
POWER CONNECTOR: P3	Screw terminals
SIGNAL CONNECTORS: P1, P2	P1 is a 26 pin high density female D-sub connector and P2 is a 15 pin high density female D-sub connector.
SIZE	8.00 x 5.62 x 1.60 inches 203.2 x 142.9 x 40.7 mm
WEIGHT	2.12 lb. 0.99 Kg

* Low inductance motors require external inductors.

PIN FUNCTIONS:

CONNECTOR	PIN	NAME	DESCRIPTION / NOTES	I/O
P1	1	+10V @ 3 mA	For customer use	O
	2	SIGNAL GND	Reference ground	SGND
	3	-10V @ 3 mA	For customer use	O
	4	+REF	Differential reference input, maximum $\pm 15V$, 20K input resistance	I
	5	-REF		
	6	Velocity Input	Single ended reference input, external velocity signal, maximum $\pm 15V$, 10K input resistance	I
	7	Velocity Monitor	SW2-3=OFF; 1 V = 25 kHz Encoder frequency, maximum 250 KHz SW2-3=ON; 1 V = 175 kHz Encoder frequency, maximum 1.75 MHz	O
	8	Current Monitor	This signal is proportional to the RMS current in the motor leads. Models SE10A: 1V = 1.33 A Models SE30A: 1V = 4 A	O
	9	Current Reference	This is the command signal to the internal current-loop. The maximum peak current rating of the amplifier always equals 7.25 V at this pin. Models SE10A: SW1-3=ON, 7.25V=10A; SW1-3=OFF, 7.25V=5A. Models SE30A: SW1-3=ON, 7.25V=30A; SW1-3=OFF, 7.25V=15A.	O
	10	Phase	TTL level output: Output is low when commutating in trapezoidal mode and will be high when the amplifier is commutating sinusoidally.	O
	11	Inhibit/Enable	This TTL level input signal turns off all power devices of the "H" bridge when pulled to ground with SW1-6=ON. If SW1-6 = OFF pulling this pin to ground will enable the amplifier. This inhibit will cause a fault condition and a red LED. For inverted inhibit inputs, see section "G".	I
	12	+Inhibit/Enable	If SW1-6=ON, pull P1-12 to ground to inhibit (+) amplifier output and P1-13 to inhibit (-) amplifier output. If SW1-6=OFF, pull P1-12 to ground to enable (+) amplifier output and P1-13 to enable (-) amplifier output. These inputs will NOT cause a fault condition or a red LED.	I
	13	-Inhibit/Enable		I
	14	Fault (LED red)	TTL level output. Becomes high during output short circuit, over-voltage, inhibit, over-temperature and during power-on reset. Fault condition indicated by red LED.	O
	15	+5V @ 250mA	For customer use. Note: the total current on P1-15 and P2-13 combined should not exceed 250 mA.	O
	16	SIGNAL GND	Reference ground	SGND
	17	Controller Power*	Connected to P2-15. For customer use	I
	18	Controller Line 1*	Connected to P2-10. For customer use	I
	19	Controller Line 2*	Connected to P2-11. For customer use	I
	20	Encoder Channel A+	Differential Encoder Output (from connector P2)	O
	21	Encoder Channel A-		
	22	Encoder Channel B+	Differential Encoder Output (from connector P2)	O
	23	Encoder Channel B-		
	24	Index+	Differential Encoder Output (from connector P2)	O
	25	Index-		
	26	Reserved		

NOTE: All circuits on connectors P1 and P2 are optically isolated from all circuits on connector P3.
* No connection internal to the amplifier. See block diagram.

PIN FUNCTIONS:

CONNECTOR	PIN	NAME	DESCRIPTION / NOTES	I/O
P2	1	HALL 1	Hall sensor inputs, internal 2K pull-up, logic levels: maximum low level input is 1.5VDC, minimum high level input is 3.5VDC	I
	2	HALL 2		
	3	HALL 3		
	4	Encoder Channel A+	Differential Encoder Input	I
	5	Encoder Channel A-		
	6	Encoder Channel B+	Differential Encoder Input	I
	7	Encoder Channel B-		
	8	Encoder Channel I+	Differential Encoder Input (Not Required)	I
	9	Encoder Channel I-		
	10	Controller Line 1*	Connected to P1-18. For customer use.	O
	11	Controller Line 2*	Connected to P1-19. For customer use.	O
	12	Signal GND	Reference ground	SGND
	13	+5V @ 250mA	For customer use. Note: the total current on P1-15 and P2-13 combined should not exceed 250 mA.	O
	14	TACH	Tachometer Input, 60 K Ω input resistance, \pm 60 V max.	I
	15	Controller power*	Connected to P1-17. For customer use.	O
P3	1	MOTOR A	Motor phase A connection	O
	2	MOTOR B	Motor phase B connection	O
	3	MOTOR C	Motor phase C connection	O
	4	POWER GND	Power ground	PGND
	5	HIGH VOLTAGE	DC power input	I

NOTE: All circuits on connectors P1 and P2 are optically isolated from all circuits on connector P3.

* No connection internal to the amplifier. See block diagram.

SWITCH FUNCTIONS:**BANK 1**

SWITCH	FUNCTION DESCRIPTION	SETTING	
		ON	OFF
1-1	Test / Offset controls the sensitivity of the "offset" pot. This is used as an on-board reference signal in test mode.	Test	Offset
1-2	Current loop gain*	Decrease	Increase
1-3	Current scaling. When OFF, this increases the sensitivity of the current sense thus reducing both peak and continuous current limit by 50%.	100%	50%
1-4	Continuous current reduction	Continuous / peak current limit ratio is 50%	Continuous / peak current limit ratio is 25%
1-5	60/120 degree commutation phasing	120 degree phasing	60 degree phasing
1-6	INHIBIT/ENABLE	P1-11, 12, 13 : INHIBIT	P1-11, 12, 13 : ENABLE

* See item "6.3 Current Loop Adjustments" in section G for more information.

Units are shipped set for ½ current output via SW1-3=off and in the disabled state via SW1-6=off.

BANK 2

SWITCH	FUNCTION DESCRIPTION	SETTING	
		ON	OFF
2-1	Encoder Velocity feedback. This connects the internally generated velocity signal from the encoder.	Encoder velocity feedback enabled.	Encoder velocity feedback disabled.
2-2	Reserved	Must be OFF.	
2-3	Velocity Monitor Scaling	1V=175 KHz	1V=25 KHz
2-4	Velocity Feedback Polarity	Toggles the polarity of the encoder velocity feedback.	
2-5	Loop integrator. This capacitor normally ensures "error-free" operation in velocity mode by reducing the error signal (output of summing amplifier) to zero.	Disables velocity / voltage loop integrator capacitor	Enables velocity / voltage loop integrator capacitor
2-6	Integrator capacitor. This adjusts the value of the integrator capacitor in the velocity mode.	Increase	Decrease

POTENTIOMETER FUNCTIONS:

POTENTIOMETER	DESCRIPTION	TURNING CW
Pot 1	This potentiometer is the loop gain adjustment in the velocity mode. Turn this pot fully CCW in current mode.	Increases loop gain
Pot 2	Current limit. This potentiometer adjusts both the continuous and peak current limit while maintaining a selected ratio.	Increases current limit
Pot 3	Reference in gain. This potentiometer adjusts the ratio between input signal and output variables (current, velocity).	Increases reference input gain
Pot 4	Test / Offset. Used to adjust any imbalance in the input signal or in the amplifier. When SW1-1 (DIP switch) is ON, the sensitivity of this pot is greatly increased allowing it to be used as an on-board signal source for testing purposes.	N/A

TEST POINTS FOR POTENTIOMETERS: See section "G".

OPERATING MODE SELECTION:**FEEDBACK MODE**

The following operating modes can be selected by setting the DIP switches according to the following chart:

- Current mode
- Encoder velocity mode
- External velocity mode
- Tachometer mode

MODE	SW1-1	SW1-2	SW1-3	SW1-4	SW1-5	SW1-6	SW2-1	SW2-2	SW2-3	SW2-4	SW2-5	SW2-6
Current Mode	X	X	X	X	X	X	OFF	OFF	OFF	X	ON	OFF
Encoder Velocity Mode	X	X	X	X	X	X	ON	OFF	OFF	X	OFF	X
External velocity mode	X	X	X	X	X	X	OFF	OFF	OFF	X	OFF	X
Tachometer mode	X	X	X	X	X	X	OFF	OFF	OFF	X	OFF	X

X does not affect mode.

120°/60° PHASE SENSOR START UP:

In sinusoidal mode, the motor will be commutated using the Hall sensors for a minimum of one torque cycle and a maximum of two torque cycles to synchronize the motor phases with the encoder. Once the phases are synchronized the amplifier will commutate the motor sinusoidally. The In-phase indicator will indicate when the amplifier is commutating sinusoidally. If the encoder signals are lost the amplifier will commutate the motor using the Hall sensors and then attempt to re-synchronize the motor phase with the encoder. The In-phase output will deactivate when the amplifier is commutating using Hall sensors.

APPLICATION NOTE: For proper operation, P1-6, and P2-14 must be connected to the signal ground if they are not being used.

SET-UP: See section "G" for engineering and installation notes.

CURRENT LIMIT ADJUSTMENTS:

These amplifiers feature separate peak and continuous current limit adjustments. The current limit adjustment Pot 2 adjusts both peak and continuous current limit at the same time. It has 12 active turns and one inactive turn at each end. This pot is approximately linear. Thus, to adjust the current limit turn the potentiometer counter-clockwise to zero, then turn clockwise to the appropriate value. In many applications it is sufficient to use only the DIP-switches for current limit adjustments. SW1-3 reduces both peak and continuous current limit by 50% when OFF. SW1-4 reduces only the continuous current limit by 50% when OFF:

SW1-4	CONTINUOUS / PEAK CURRENT LIMIT RATIO
ON	50%
OFF	25%

P1-9 is the input to the internal current amplifier power stage. Since the output current is proportional to P1-9, the adjusted current limit can easily be observed at this pin without connecting the motor. Note that a command signal must be applied to the reference inputs to obtain a reading on P1-9. The maximum peak current value equals 7.25 V at this pin and the maximum continuous current value equals 3.63 V at this pin. If SW1-3=ON, peak rated amplifier current = 7.25 V. If SW1-3=OFF, $\frac{1}{2}$ peak rated amplifier current = 7.25 V. Example: using the SE30A20 with SW1-3=ON, 30A=7.25V and with SW1-3=OFF, 15A=7.25V.

The actual output current can be monitored at pin P1-8.

TYPICAL SYSTEM WIRING: See section "G".

MATING CONNECTORS:

Manufacturer: AMP® (Tel: 1-800-522-6752)

Part numbers:

15 Pin plug 748364-1
26 Pin plug 748365-1

Pins 748333-2

Shell Kit (plastic with metal coating)

15 Pin 748677-1
26 Pin 748677-2

SE30A Series

ORDERING INFORMATION:

Models: SE10A8X, SE10A20X, SE10A40X, SE30A8X, SE30A20X and SE30A40X

*Divide by 4 option

Models: SE10A8X-4, SE10A20X-4, SE10A40X-4, SE30A8X-4, SE30A20X-4 and SE30A40X-4

*Divide by 8 option

Models: SE10A8X-8, SE10A20X-8, SE10A40X-8, SE30A8X-8, SE30A20X-8 and SE30A40X-8

*Divide by 16 option

Models: SE10A8X-16, SE10A20X-16, SE10A40X-16, SE30A8X-16, SE30A20X-16 and SE30A40X-16

*For use with high-resolution encoders, contact the factory to determine which option is best for your application

X indicates the current revision letter.

MOUNTING DIMENSIONS: See page F-13.