

## DIGIFLEX® DIGITAL SERVO DRIVES MODEL: ZDR150EE12A8LDC

### FEATURES:

- Fully digital, state-of-the-art design
- Space Vector Modulation and vector control technology
- 20kHz Digital current loop with programmable gain settings
- PIDF velocity loop with 100 microsecond update rate
- PID + FF position loop with 100 microsecond update rate
- Hall sensor + encoder or encoder-only based commutation
- Surface-mount technology
- Small size, low cost, ease of use
  
- RS232 interface for setup and configuration
- Windows© based setup software with built-in 8-channel digital scope
- Operates in torque, velocity or position mode with programmable gain settings
- Programmable profiling in all modes
- Fully configurable current, voltage, velocity and position limits.
- Step & direction mode for stepper replacement
- Encoder following with programmable gear ratio
  
- 3 programmable digital inputs
- 2 programmable differential inputs, configurable as step & direction, master encoder, or secondary encoder for dual loop operation
- 3 programmable digital outputs
- 12-bit reference input or programmable analog input
  
- Four quadrant regenerative operation
- Separate logic supply input
- Extensive built-in protection against:
  - over-voltage (programmable)
  - under-voltage (programmable)
  - short-circuit: phase-phase, phase-ground
  - over-current
  - over-temperature
- Optional mounting card MC1XZDR for easy interfacing

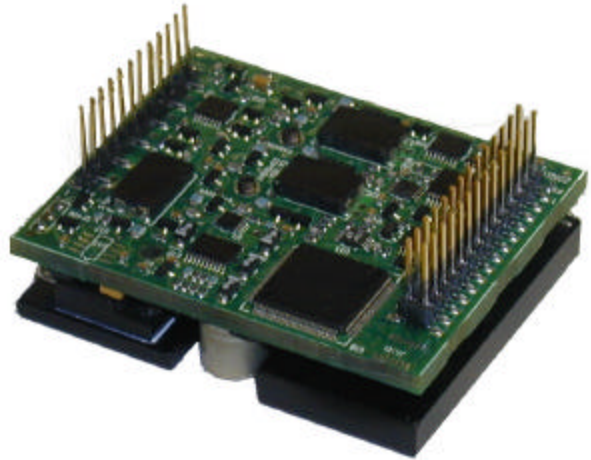

**▲ ADVANCED MOTION CONTROLS**

3805 Calle Tecate, Camarillo, CA 93012  
Tel: (805) 389-1935, Fax: (805) 389-1165

**BLOCK DIAGRAM:**

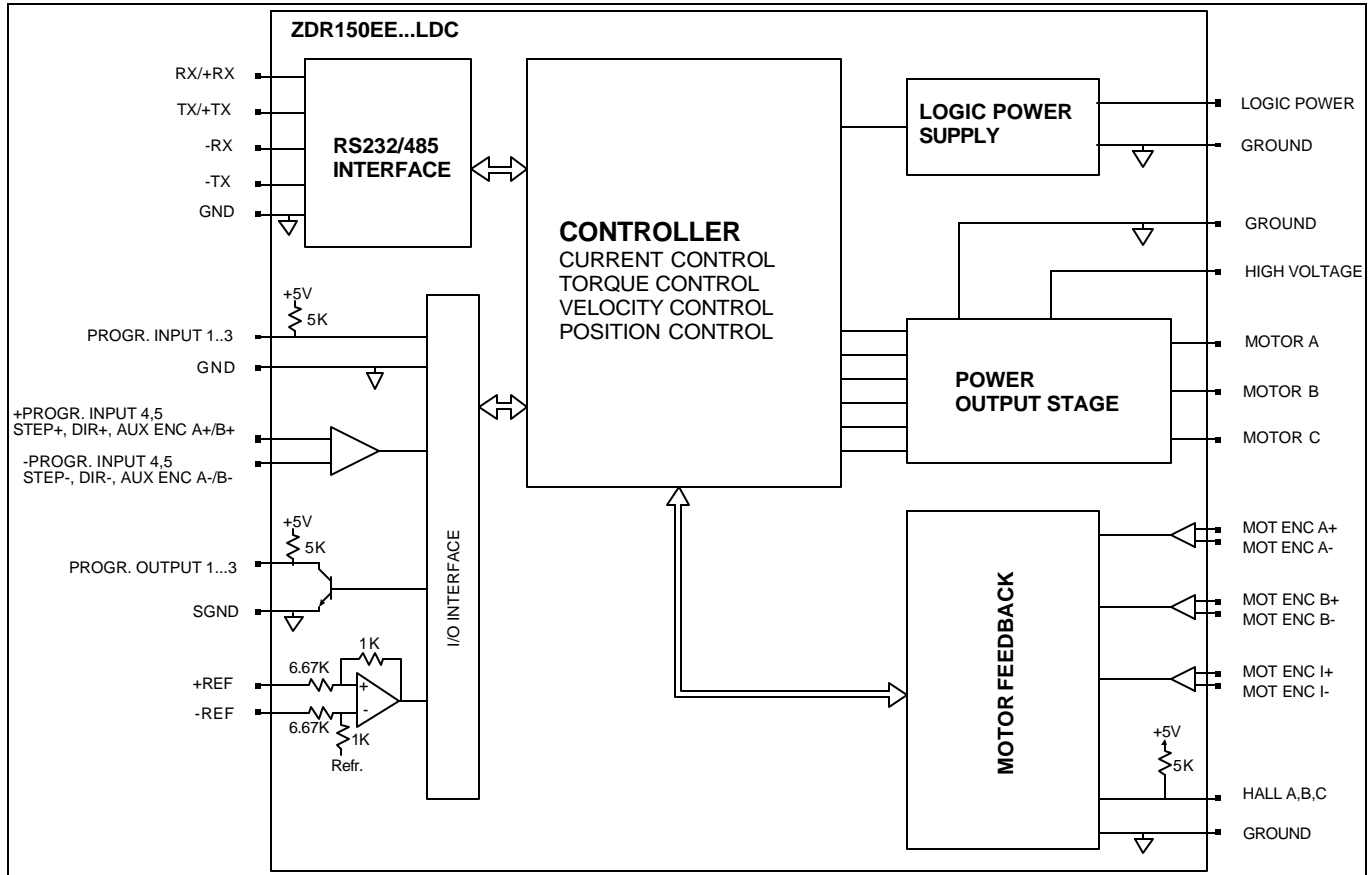

**DESCRIPTION:**

The ZDR150EE Series digital PWM servo drives are designed to drive brushed and brushless servomotors. These fully digital drives operate in torque, velocity, or position mode and employ Space Vector Modulation (SVM), which results in higher bus voltage utilization and reduced heat dissipation. The command source can be generated internally or can be supplied externally. In addition to motor control, these drives feature dedicated and programmable digital and analog inputs and outputs to enhance interfacing with external controllers and devices.

ZDR150EE Series drives feature a single RS232 interface, which is used for drive configuration and setup. Drive commissioning can be accomplished through a fully graphical Windows® based application.

All drive and motor parameters are stored in non-volatile memory.

**SPECIFICATIONS:**

<b>POWER STAGE SPECIFICATIONS</b>	<b>ZDR150EE12A8LDC</b>
DC SUPPLY VOLTAGE (HV IN)	20...60 VDC
LOGIC SUPPLY VOLTAGE	5 VDC (+/- 5%) @ 0.4A + current consumption of feedback and I/O. <b>CAUTION: make sure the +5V IN is applied, prior to applying the HV IN. Applying HV IN before the +5V IN may cause damage to the drive.</b>
PEAK CURRENT	12A (8.6Arms)
MAXIMUM CONTINUOUS CURRENT	6A (4.3Arms)
MINIMUM LOAD INDUCTANCE	250 $\mu$ H
SWITCHING FREQUENCY	20 kHz
HEATSINK (BASEPLATE) TEMPERATURE RANGE	0 to 65 °C, disables at 65 °C
POWER DISSIPATION AT CONTINUOUS CURRENT	See thermal data below
MIN. UNDER VOLTAGE SHUTDOWN	17 VDC
MAX. OVER-VOLTAGE SHUTDOWN	86 VDC

<b>MECHANICAL SPECIFICATIONS</b>	
POWER CONNECTOR: P2	Single row header, 0.1 inch (2.54 mm) spacing
SIGNAL CONNECTOR: P1	Dual row header, 0.1 inch (2.54 mm) spacing
SIZE	2.5 x 2.0 x 0.73 inches 63.5 x 50.8 x 18.5 mm
WEIGHT	3.4 oz 95.2 g

**Thermal Data:**

Note: please allow 10% variation on all obtained results and size additional heat sinking or cooling accordingly.

The ZDR drive has two sources of heat generation: heat generated by the internal logic, and heat generated by the power output stage. The base plate temperature change caused by these two sources is different due to the internal construction of the drive. The thermal impedance of the internal logic section is approximately:

$$Z_L = 6.25 \text{ }^\circ\text{C/Watt}$$

The thermal impedance of the power output stage is approximately:

$$Z_O = 8.5 \text{ }^\circ\text{C/Watt}$$

The heat generation of the logic section is:

$$W_L = 2 \text{ Watts} + \text{heat dissipated in I/O circuit}$$

The heat dissipation in the I/O circuit can be calculated from the current through the input and output impedances. This is typically very small and negligible.

Hence the temperature change due to the logic circuit is approximately:

$$\Delta T = Z_L * W_L = 12.5 \text{ }^\circ\text{C}$$

The heat generation of the output stage is:

Output Stage Dissipation Vs. Output Current

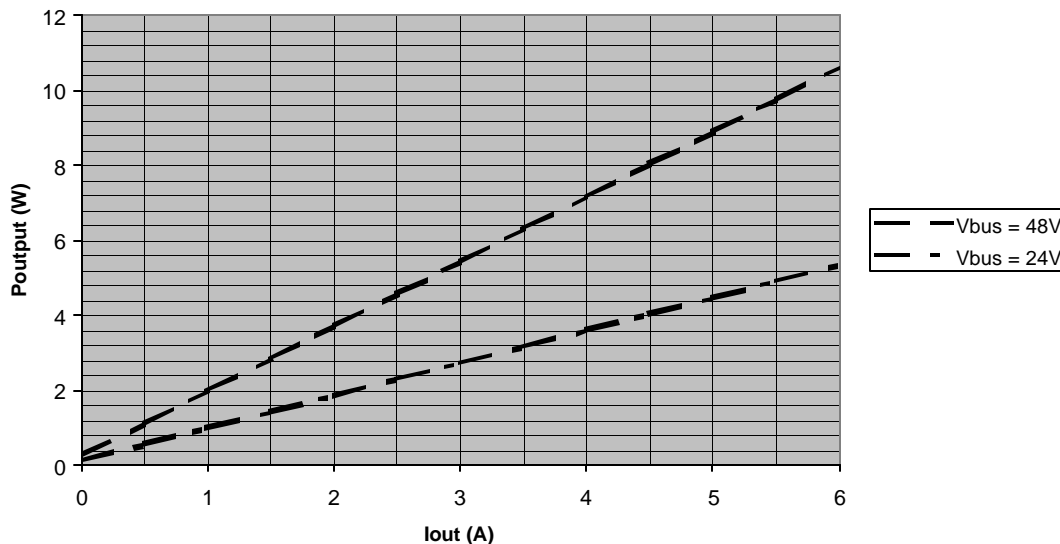

For example, at  $V_{bus} = 24\text{VDC}$ ,  $I_{out} = 4\text{A}$ ,  $P_O = 3.6\text{ Watts}$ . Hence the temperature change due to the power output stage is:

$$\Delta T = Z_O * W_O = 30.6\text{ }^\circ\text{C}$$

The total base plate temperature change is  $43.1\text{ }^\circ\text{C}$ . Hence in a  $25\text{ }^\circ\text{C}$  ambient, the drive would shut down due to drive over temperature ( $65\text{ }^\circ\text{C}$ ).

Additional heat sinking and/or cooling needs to be sized such that the base plate temperature stays below  $65\text{ }^\circ\text{C}$  to avoid over-temperature drive shutdown.

## MC1XZDR MOUNTING CARD 1-Axis ZDR Series Interface Board

**FEATURES:**

- Single axis mounting card
- Small footprint
- All pluggable connections
- On-board signal conditioning
- Screw terminal or D-Sub for signal connections
- Screw terminal mating connectors included
- Tight fitting connectors
- Standard DIN tray dimensions

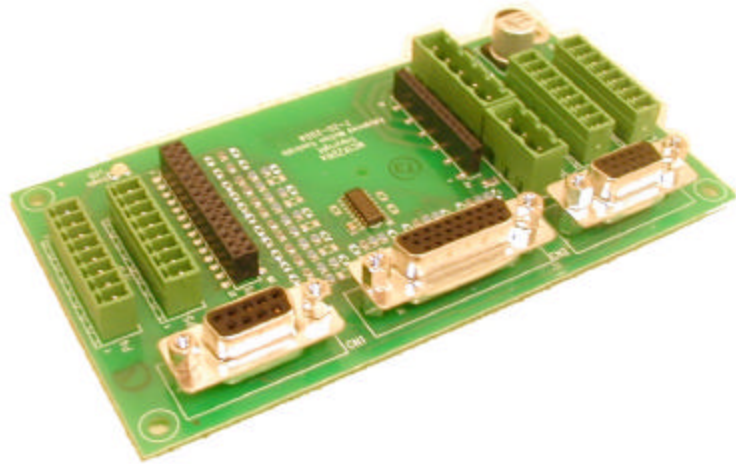

**BLOCK DIAGRAM:**

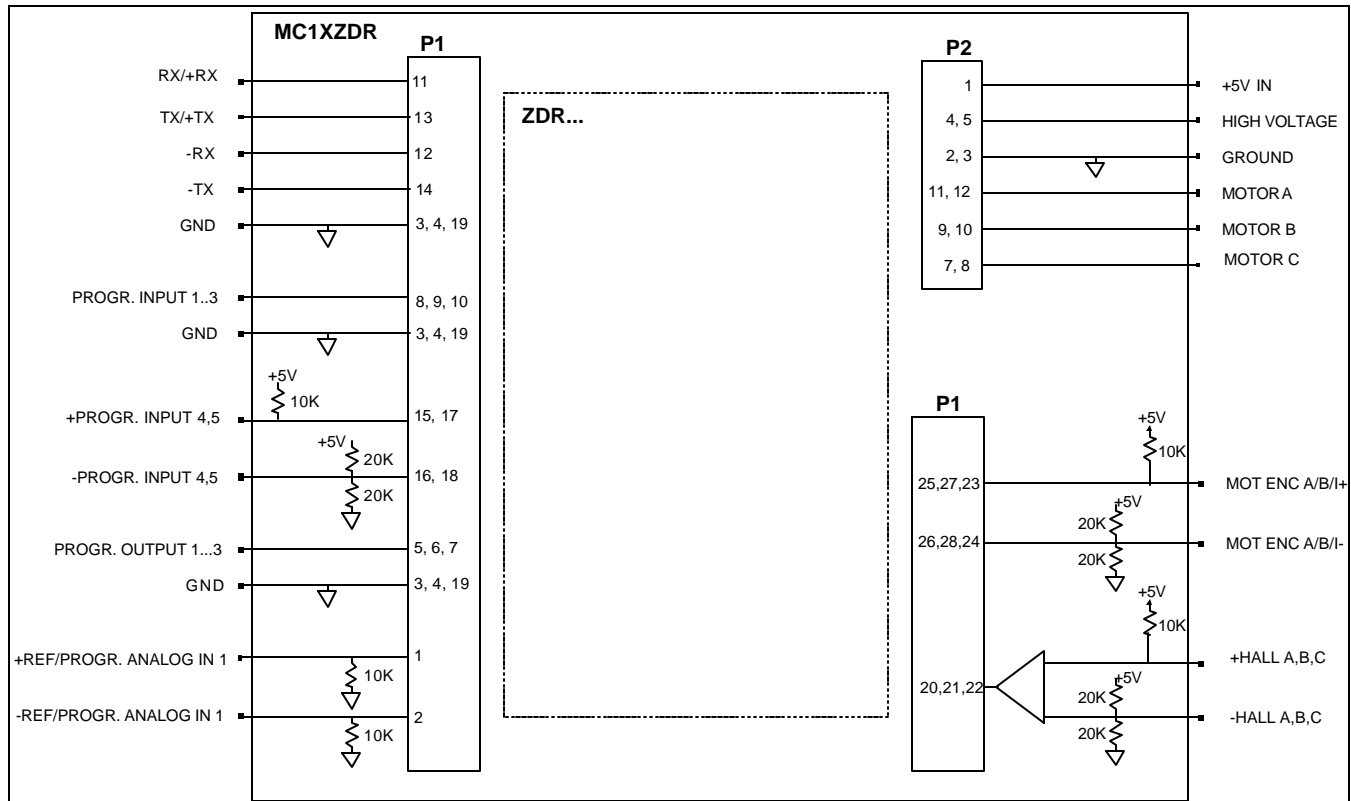

**DESCRIPTION:** The MC1XZDR mounting card is designed to host a ZDR Series DigiFlex® servo drive. This mounting card offers convenient pluggable screw terminals and D-Sub connectors for easy interfacing. D-sub connectors are compatible with DR100EE series. A logic LED and power LED indicate supply status.

**SPECIFICATIONS:**

<b>MECHANICAL SPECIFICATIONS</b>	
MOTOR AND POWER CONNECTOR	5-position 5.08 mm spaced header*
LOGIC SUPPLY CONNECTOR	3-position 5.08 mm spaced header*
FEEDBACK CONNECTORS	2x 8-position 3.5 mm spaced header* or 15-pin high density D-sub
INPUT/OUTPUT CONNECTORS	2x 8-position 3.5 mm spaced header* or 26-pin high density D-sub
SERIAL INTERFACE CONNECTOR	Female 9-pin D-sub
SIZE (without drive or mating connectors)	6.55 x 2.83 x 0.64 inches
WEIGHT (without drive or mating connectors)	

\* Mating connectors included

**PIN FUNCTIONS:**

P3A & P3B & CN3- Motor Feedback Connectors:

CON.	PIN	NAME	DESCRIPTION	I/O	PIN	CON.
P3A	1	+5V	5V output from 5V logic supply	O	13	CN3
	2	GND	Ground	GND	12	
	3	+Hall A	Commutation sensor input. Can be used with single ended or differential Hall sensors.	I	1	
	4	-Hall A	Leave open in case of single ended Hall sensors.	I	10	
	5	+Hall B	Commutation sensor input. Can be used with single ended or differential Hall sensors.	I	2	
	6	-Hall B	Leave open in case of single ended Hall sensors.	I	11	
	7	+Hall C	Commutation sensor input. Can be used with single ended or differential Hall sensors.	I	3	
	8	-Hall C	Leave open in case of single ended Hall sensors.	I	15	

CON.	PIN	NAME	DESCRIPTION	I/O	PIN	CON.
P3B	1	+5V	5V output from 5V logic supply	O	13	CN3
	2	GND	Ground	GND	12	
	3	MOT ENC A+	Differential Encoder Input. For single ended encoder signals, leave the A-terminal open.	I	4	
	4	MOT ENC A-		I	5	
	5	MOT ENC B+	Differential Encoder Input. For single ended encoder signals, leave the B-terminal open.	I	6	
	6	MOT ENC B-		I	7	
	7	MOT ENC I+	Differential Encoder Input. For single ended encoder signals, leave the I-terminal open.	I	8	
	8	MOT ENC I-		I	9	

P4 & P5 & CN2- I/O Connectors:

CON.	PIN	NAME	DESCRIPTION	I/O	PIN	CON.
P4	1	+REF	Differential reference signal input, 12-bit resolution. Can also be used as programmable analog input 1.	I	4	CN2
	2	-REF		I	5	
	3	GND	Ground	GND	2,16	
	4	GND	Ground	GND	2,16	
	5	PDO1	Programmable digital output	O	1	
	6	PDO2	Programmable digital output	O	3	
	7	PDO3	Programmable digital output	O	10	
	8	GND	Ground	GND	2	

CON.	PIN	NAME	DESCRIPTION	I/O	PIN	CON.
P5	1	PDI1	Programmable digital input	I	11	CN2
	2	PDI2	Programmable digital input	I	12	
	3	PDI3	Programmable digital input	I	13	
	4	GND	Ground	GND	2,16	
	5	+PDI4	Programmable differential digital input, or Step+/Step- or Aux Enc A+/A-	I	17	
	6	-PDI4		I	26	
	7	+PDI5	Programmable, differential digital input or Direction+/Direction - or Aux Enc B+/B-	I	18	
	8	-PDI5		I	9	

Additional CN2 Pin Functions:

CON.	PIN	NAME	DESCRIPTION	I/O
CN2	6	-		
	7	-		
	8	-		
	14	-		
	15	+5V OUT	5V output from 5V logic supply	
	19	-		
	20	Encoder Channel A+	Encoder Output (from connector P3B, CN3), not buffered	O
	21	Encoder Channel A-		O
	22	Encoder Channel B+	Encoder Output (from connector P3B, CN3), not buffered	O
	23	Encoder Channel B-		O
	24	Encoder Channel I+	Encoder Output (from connector P3B, CN3), not buffered	O
	25	Encoder Channel I-		O

P6 - Motor and Power Connector:

CON.	PIN	NAME	DESCRIPTION	I/O
P6	1	A	Motor phase A	O
	2	B	Motor phase B	O
	3	C	Motor phase C	O
	4	GND	Ground	GND
	5	+HV	DC motor power input. This input is used to supply power to the motor.	I

P7 - Logic Power Connector:

CON.	PIN	NAME	DESCRIPTION	I/O
P7	1	+5V	5V logic supply	I

	2	GND	Ground	GND
	3	CHASSIS	Connected to CN1, CN2, CN3 shields	CHS

CN1 - Communications Interface (RS232):

CON.	PIN	NAME	DESCRIPTION	I/O
CN1	1	N/C	Not connected	
	2	TX	RS232: Transmit	O
	3	RX	RS232: Receive	I
	4	N/C	Not connected	
	5	GND	Signal ground	GND
	6			
	7	N/C	Not connected	
	8			
	9	N/C	Not connected	

**MATING CONNECTORS:**

- Included connectors: Manufacturer Phoenix Contact ® (Tel: 717-944-1300)
  - 3-position 5.08 mm spaced plug terminal (1 qty) 1757022
  - 5-position 5.08 mm spaced plug terminal (1 qty) 1757048
  - 8-position 3.5 mm spaced plug terminal (4 qty) 1840421
- Alternative 5.08 mm spaced plug terminals (vertical screw position)
  - 3-position plug 1777293
  - 5-position plug 1777316
- Non-included connectors: Subminiature D-Shell, Mfg: AMP, www.amp.com, Phone: 800-522-6752
  - 15-pin (high density)
    - Plug: 748364-1
    - Shell Kit: 748677-1
    - Pins: 748333-2 (strip)
    - 748333-4 (loose)
  - 26-pin (high density)
    - Plug: 748365-1
    - Shell Kit: 748677-2
    - Pins: 748333-2 (strip)
    - 748333-4 (loose)
  - 9-pin (Standard)
    - Plug: 205204-4
    - Shell Kit: 748677-1
    - Pins: 5-66507-7 (loose)
    - 3-66507-0 (strip)

**DIN RAIL MOUNTING**

The MC1XZDR mounting card is designed to easily slide into a standard sized DIN mounting tray. The photo below shows a ZDR Series drive installed onto the MC1XZDR, which is inserted in a DIN mounting tray on a DIN rail. Mounting tray, DIN rail and drive are not included.

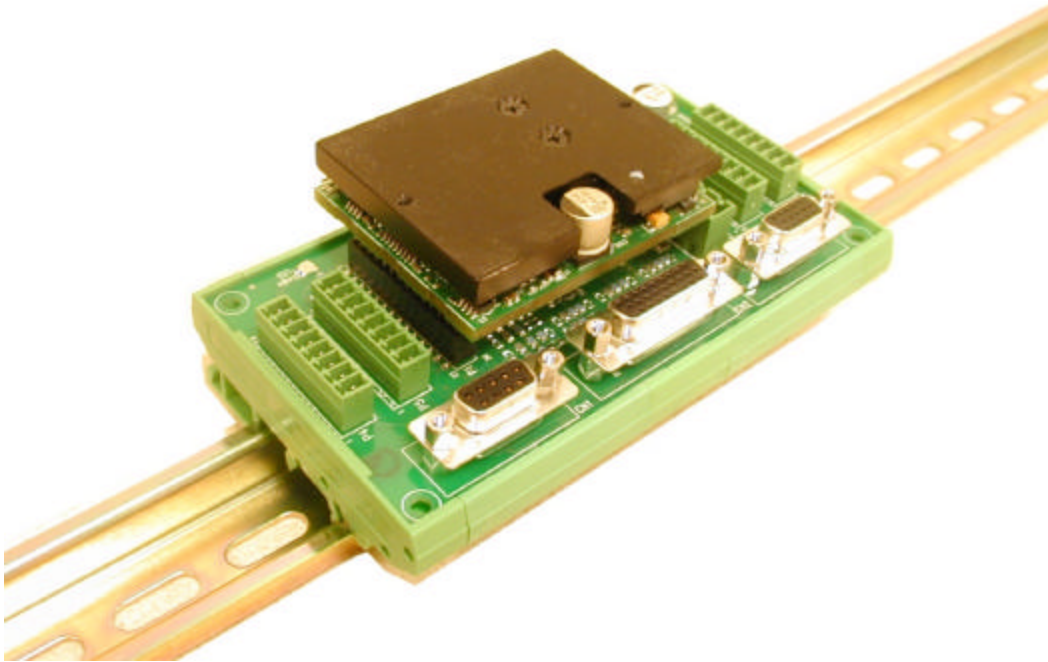
**ORDERING INFORMATION:**

Standard model: ZDR150EE12A8LDCX

X indicates the current revision letter.

Model: MC1XZDRX

X (at the end) indicates current revision letter

**MOUNTING DIMENSIONS:**

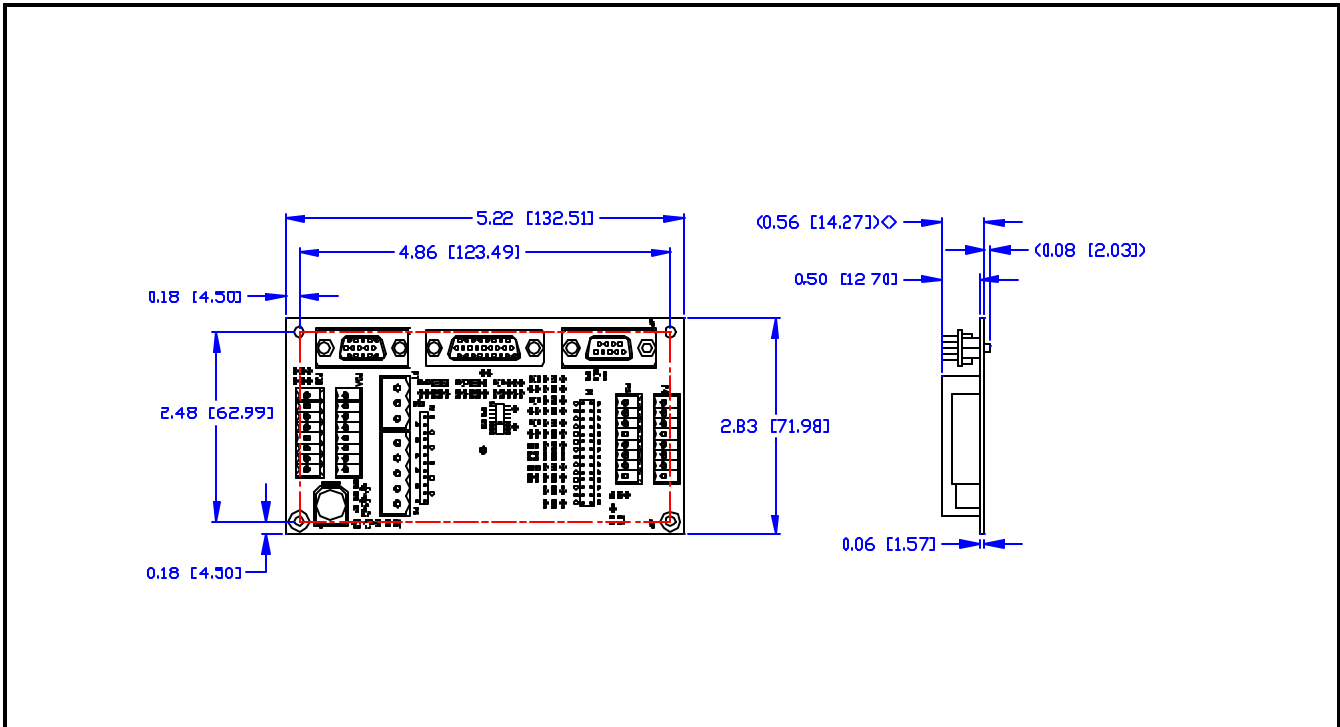

1. DIMENSIONS IN [ ] ARE IN MM  
 NOTES: UNLESS OTHERWISE SPECIFIED.

	A	INITIAL RELEASE	08/13/04	RB	
	REV	DESCRIPTION	DATE	BY	ECD
	UNLESS OTHERWISE SPECIFIED, DIMENSIONS ARE IN INCHES		<p><b>ADVANCED MOTION CONTROLS</b>                  • PWM SERVO AMPLIFIERS •                  3806 Calle Tecate, Camarillo, CA 93012</p>		
	TOLERANCES				
	XXX ± .001				
	XXX ± .005				
	DO NOT SCALE DRAWING		TITLE		
	DRAWN BY:	DATE:	MOUNTING DIMENSIONS, MCLXZDR		
	R. BAUTISTA	08/13/04			
	CHECK BY:	DATE:	SIZE	DWG. NO.	REV
			B	MCMC1XZDR	A
	DESIGN APPROVED	DATE:	SCALE	SHT. 1 OF 1	
	USED ON		FULL		