



## Short Form Installation Guide

### Models:

DR100RE15A8BDC	DR100RE60A40NAC
DR100RE25A20NAC	
DR100RE30A40NDC	
DR100RE30A40LDC	
DR100RE30A40NAC	
DR100RE60A40NDC	

Document Reference: SFIG-DR100RE

Revision: 1.0

Date: January 27, 2003

3805 Calle Tecate, Camarillo, CA 93012  
Tel: (805) 389-1935, Fax: (805) 389-1165  
<http://www.a-m-c.com>

## Preface

### Installation & Operation of the Equipment

It is important that Advanced Motion Controls (AMC) motion control equipment is installed and operated in such a way that all applicable safety requirements are met. It is your responsibility as a user to ensure that you identify the relevant standards and comply with them. Failure to do so may result in damage to equipment and personal injury.

Read this entire manual prior to attempting to install or operate the drive. By reading the manual you will become familiar with practices and procedures that allow you to operate these drives safely and effectively. As a user or person installing these drives, you are responsible for determining the suitability of this product for the intended application. AMC is neither responsible nor liable for indirect or consequential damages resulting from the inappropriate use of this product.

### General Safety Warning

High-performance motion control equipment is capable of producing rapid movement and very high forces. Unexpected motion may occur especially during product commissioning. Keep clear of any machinery driven by servomotors and never touch them while they are in operation.

High voltages exist within enclosed units, on motor terminals, and on transformer terminals. KEEP CLEAR of these areas when power is applied to the equipment. Please review the following general safety guidelines:

- Always turn off the main power and allow sufficient time for complete discharge before making any connections to the drive.
- Make sure that the minimum inductance requirements are met. Pulse Width Modulated (PWM) amplifiers deliver a pulsed output that requires a minimum amount of load inductance for proper operation.
- Do not rotate the motor shaft without power. The motor acts as a generator and will charge up the power supply capacitors through the amplifier. Excessive speeds may cause over-voltage breakdown in the power output stage. Note that an amplifier having an internal power converter that operates from the high voltage supply will become operative.
- Do not short the motor leads at high motor speeds. When the motor is shorted, its own generated voltage may produce a current flow as high as 10 times the amplifier current. The short itself may not damage the amplifier but may damage the motor.
- Do not make any connections to any internal circuitry. Only connections to designated connectors are allowed.

**AMC constantly strives to improve all of its products. We reserve the right to modify equipment and documentation without prior notice. No part of this document may be reproduced in any form without prior written consent from AMC.**

## 1. Introduction

The objective of this short form is to provide the user with minimal installation requirements in order to quickly verify proper operation of the drive. Once all connections are made and power is applied, the user should refer to the applicable software in order to establish communication with the drive. Communication with the drive and further commissioning is covered in the relevant software help files. Please contact the factory or your local representative if you need further assistance.

## 2. Determine Drive Model

The servo drive part number (or model) can be found on the white label attached to the drive. The part number should start with “DR100RE”. If you are not certain what the drive part number is, please contact the factory or your local representative.

Note: the white label also contains a bar code and four-digit date code (year and week).

## 3. Related Documentation

In addition to this short form guide you should have:

- Drive data sheet: the latest version can be found at <http://www.a-m-c.com> under the products section.
- Drive setup software DigiFlex DriveSuite (DS): please contact the factory or your local representative to obtain the latest version.
- Start Up Guide: is included with the software or can be found on <http://www.a-m-c.com>.
- Motor and feedback data sheet

## 4. Typical Drive Connections

### RS232(485), I/O and Feedback:

Refer to the drive data sheet to properly locate the RS, I/O, and feedback connectors and their respective pin layout.

A typical, standard drive, connection is as follows:

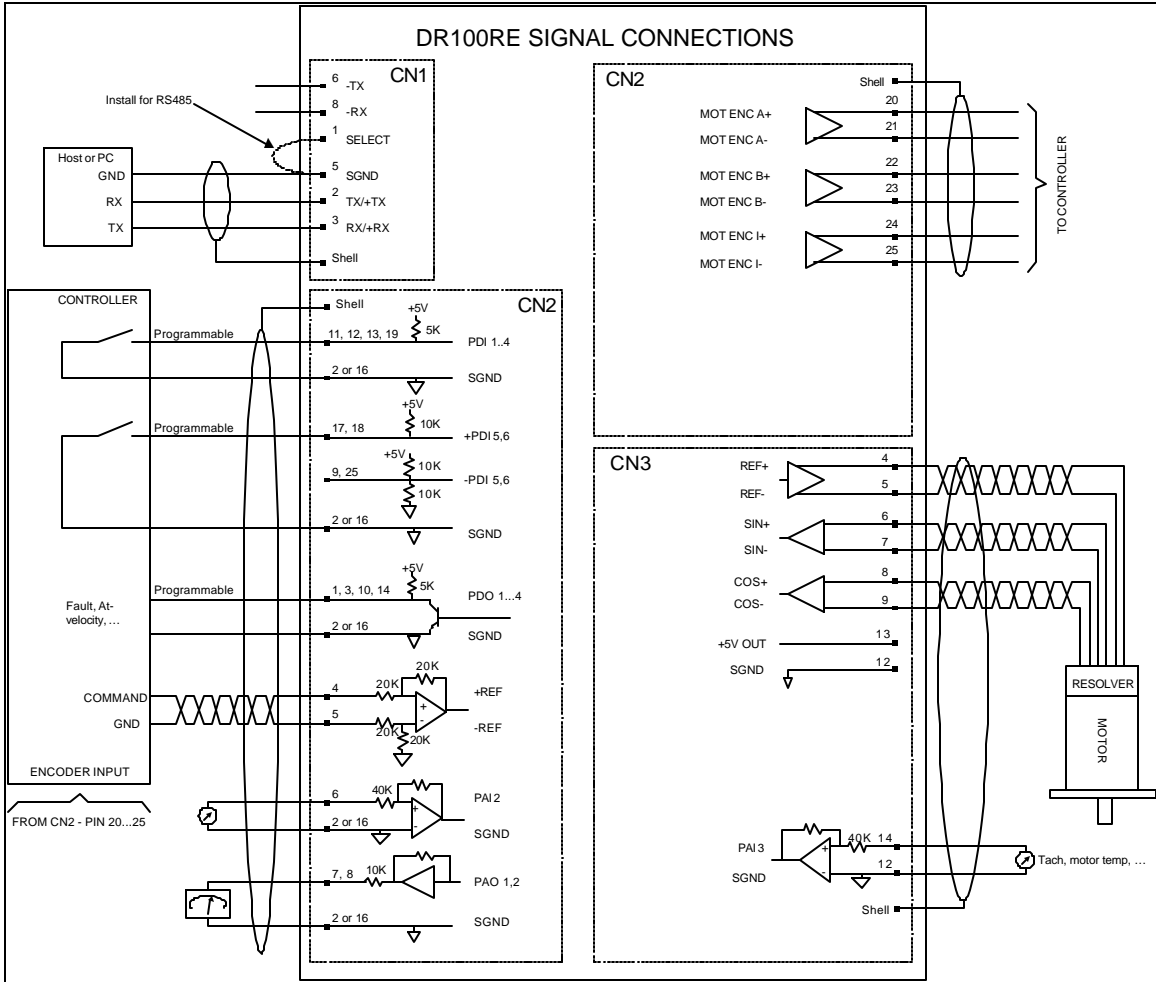

Figure 1: DR100RE signal connections

Notes:

- To establish RS232 communication with a standard PC, use a straight-through cable, e.g. mouse extension cable. Do NOT use a null-modem cable.
- RS485 communication can be selected by connecting pin 1 to pin 5 on CN1. In such case, use pin 2 and 6 for +TX/-TX, and pin 3 and 8 for +RX/-RX respectively.
- The digital input (CN2 - pin 11, 12, 13, 17, 18, 19) connections are *not required* for drive operation. The polarity of these inputs (i.e. active state) and their function can be set via the RS232 interface or DS software.
- Digital inputs 5 and 6 can be used as single ended or differential (future use for step/direction or secondary encoder).
- The digital outputs (CN2 - pin 1, 3, 10, 14) are programmable (see setup software).

- The encoder output signals on CN2, pin 20...25 are internally generated from the resolver input on CN3. Standard resolution is 12 or 14-bit (10 and 16-bit are also available, see data sheet for more details).

### Motor and Power:

Refer to the drive data sheet to properly locate the motor and power connectors and their respective pin layout. The motor and power connections will depend on the drive model.

#### DR100RE15A8BDC:

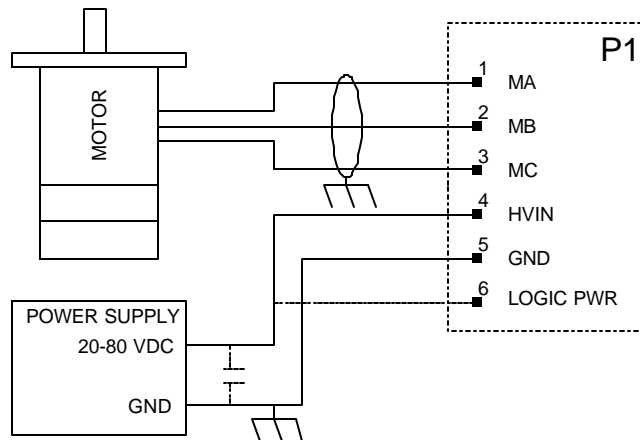
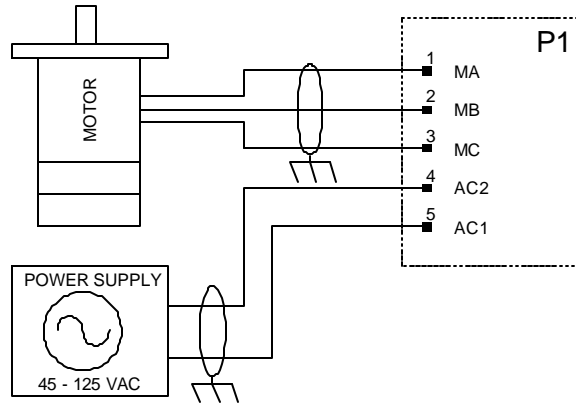

**Figure 2: DR100RE15A8BDC motor and power connections**

#### Notes:

- The use of LOGIC PWR (pin 6) is optional. It can be used to power up the internal logic circuitry, but does not provide power to the motor (i.e. does not supply power to the internal output stage). Under normal circumstances, the internal logic is powered from the voltage supplied at HVIN (pin 4).
- The use of a capacitor is optional and depends on the application.

#### DR100RE25A20NAC:



**Figure 3: DR100RE25A20NAC motor and power connections**

DR100RE30A40NAC:

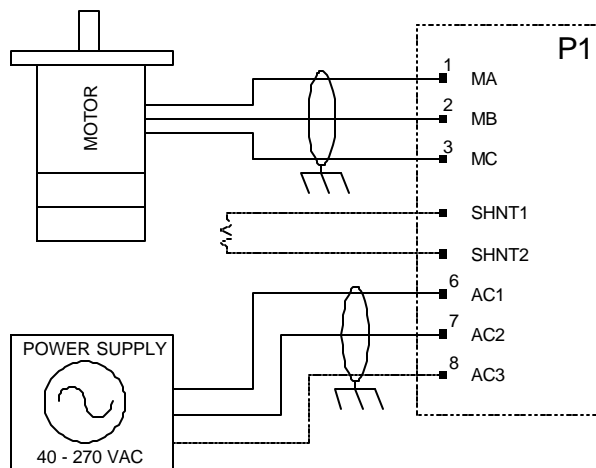
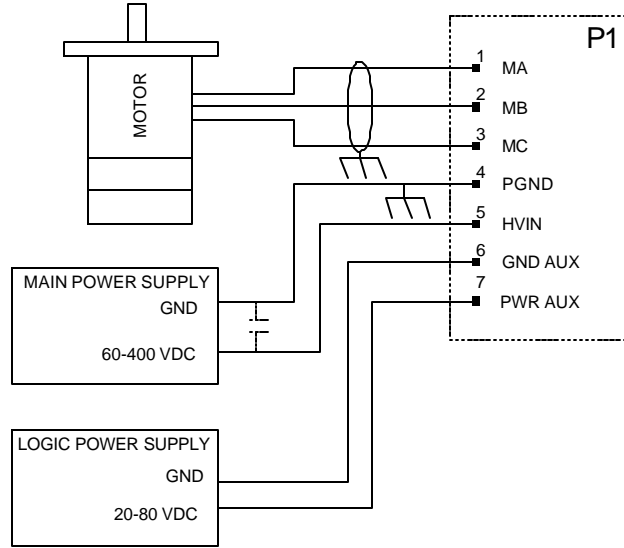

**Figure 4: DR100RE30A40NAC motor and power connections**

Notes:

- The drive can be powered with a single or three phase supply.
- The use of a shunt resistor is optional, depending on the application.

DR100RE30A40LDC:

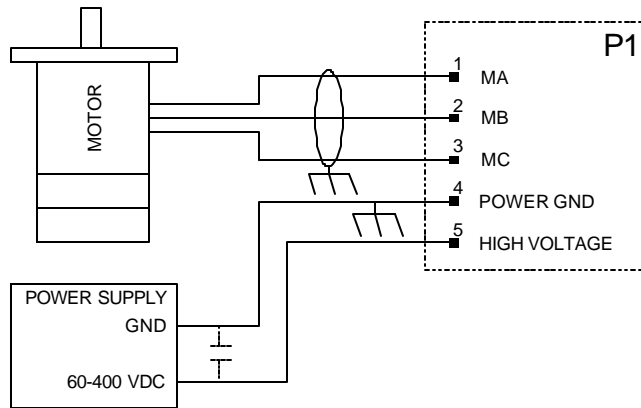

**Figure 5: DR100RE30A40LDC motor and power connections**

Notes:

- The use of a capacitor is optional and depends on the application.
- The logic power supply is *required* for proper operation.

DR100RE30A40NDC and DR100RE60A40NDC:

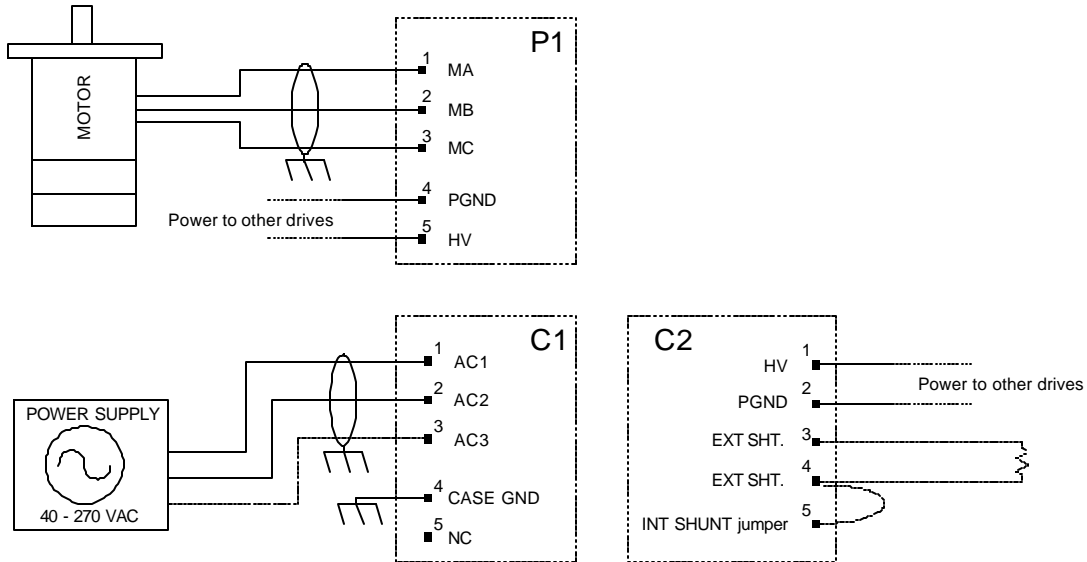

**Figure 6: DR100RE30(60)A40NDC motor and power connections**

Notes:

- The use of a capacitor is optional and depends on the application.

DR100RE60A40NAC:



**Figure 7: DR100RE60A40NAC motor and power connections**

**Notes:**

- Pin 4 and 5 of P1 and pin 1 and 2 of C2 provide access to the internal DC bus. This can be used to power other drives. The magnitude of this DC voltage is always  $1.4 \cdot V_{ac}$ .
- The drive has a built-in shunt resistor, which can be used by installing the jumper between pin 4 and 5 on C2 (factory default). If more regenerative dissipation is required, this jumper can be removed and an external resistor can be attached between pin 3 and 4 on C2.

## 5. Drive Communication and setup

Please refer to the setup software for drive communication and drive setup. The help section of the software provides detailed information on further drive commissioning.

Contact the factory or your local representative for further assistance.