

SERIES 120A10 SERVO AMPLIFIERS MODEL: 120A10

FEATURES:

- Surface-mount technology
Small size, low cost, ease of use
- Optical isolation, see block diagram
- DIP switch selectable modes:
current, voltage, velocity,
IR compensation, analog position loop
- Four quadrant regenerative operation
- Agency Approvals Pending



BLOCK DIAGRAM:

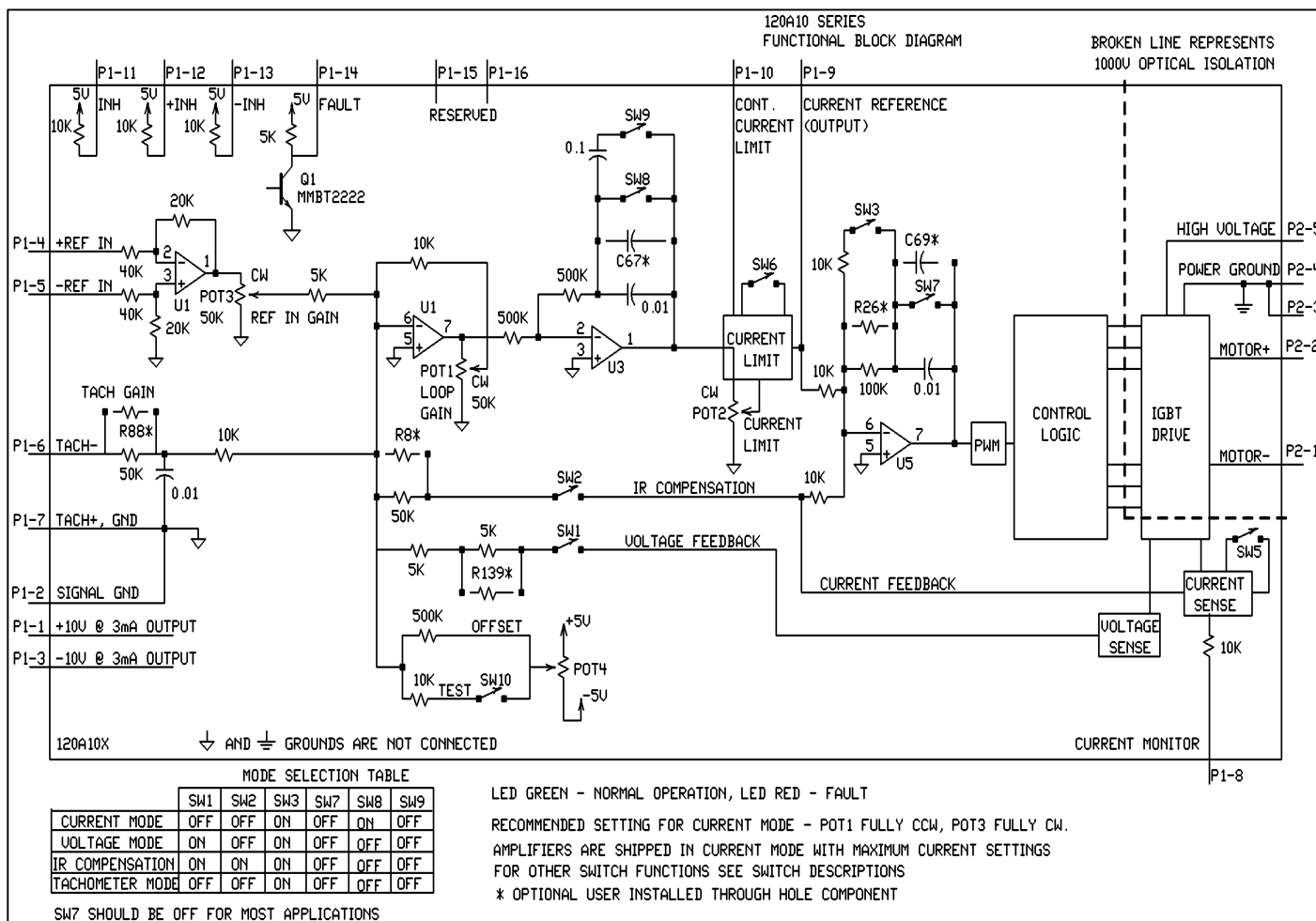

120A10 Series

DESCRIPTION: The 120A Series PWM servo amplifiers are designed to drive brush type DC motors at a high switching frequency. Single red/green LED indicates operating status. All models are fully protected against over-voltage, under-voltage, over-current, over-heating and short-circuits across motor, ground and power leads. All models interface with digital controllers or can be used as a stand-alone drive. They require only a single unregulated DC power supply. Loop gain, current limit, input gain and offset can be adjusted using 14-turn potentiometers. The offset adjusting potentiometer can also be used as an on-board input signal for testing purposes when SW10 (DIP switch) is ON.

SPECIFICATIONS:

	MODEL
POWER STAGE SPECIFICATIONS	120A10*
DC SUPPLY VOLTAGE	30 - 80 V
PEAK CURRENT (2 sec. max., internally limited)	± 120 A
MAXIMUM CONTINUOUS CURRENT (internally limited)	± 60 A
MINIMUM LOAD INDUCTANCE**	300 µH
SWITCHING FREQUENCY	15 kHz ± 15%
HEATSINK (BASE) TEMPERATURE RANGE	-25° to +65° C; disables if >65° C
POWER DISSIPATION AT CONTINUOUS CURRENT	300 W
OVER-VOLTAGE SHUT-DOWN (self-reset)	90 V
BANDWIDTH (load dependent)	2.5 kHz

MECHANICAL SPECIFICATIONS	
POWER CONNECTOR	Screw Terminals
SIGNAL CONNECTOR	16 pin Molex connector
SIZE	10 x 5.12 x 2.63 inches 254 x 130.2 x 66.7 mm
WEIGHT	3.60 lbs. 1.63 Kg.

*This model is available in a 24 V version. The part number is 120A10-24. Operating voltage is 20-40 VDC.

** Low inductance motors ("pancake" and "basket-wound") require external inductors.

PIN FUNCTIONS:

CONNECTOR	PIN	NAME	DESCRIPTION / NOTES	I/O
P1	1	+10 V OUT	Provides regulated voltages of ± 10 V @ 3 mA for customer use. Short circuit protected. P1-2 is the signal ground.	O
	2	SIGNAL GND		SGN
	3	-10 V OUT		O
	4	+REF IN	Command signal. Differential analog input, maximum ± 15 V, 40K input resistance.	I
	5	-REF IN		
	6	-TACH IN	Maximum ± 60 VDC, 60K input resistance	I
	7	+TACH (SGND)		
	8	CURRENT MONITOR OUT	This signal is proportional to the actual current in the motor leads. Scaling is 1 V = 18 A when SW5 = ON (full current) and 1 V = 9 A when SW5 = OFF.	O
	9	CURRENT REFERENCE OUT	Command signal to the internal current-loop. The maximum peak current rating of the amplifier equals 7.25 V at this pin. See current limit adjustment information below.	O
	10	CONTINUOUS CURRENT LIMIT	Can be used to reduce the factory-preset maximum continuous current limit. See current limit adjustment information below.	I
	11	INHIBIT	Inhibit. TTL, turns off all four power devices of the "H" bridge drive when pulled to ground. Will cause high FAULT and red LED. For inverted inhibit inputs; see section "G".	I
	12	+INHIBIT	Inhibits the motor for "+" direction only. This function can be useful to remove power to the motor using a "limit switch". Will not cause high FAULT or red LED.	I
	13	-INHIBIT	Inhibits the motor for "-" direction only. This function can be useful to remove power to the motor using a "limit switch". Will not cause high FAULT or red LED.	I
	14	FAULT OUT (red LED)	TTL compatible output. It becomes high during output short-circuit, over-voltage, under voltage, over-heating, inhibit, and during "power-on reset". A red LED also indicates a fault condition.	O
	15	NC	No connection.	
	16	NC	No connection.	

CONNECTOR	PIN	NAME	DESCRIPTION / NOTES	I/O
P2	1	-MOTOR	Motor minus connection.	O
	2	+MOTOR	Motor plus connection.	O
	3	POWER GROUND	Power Ground.	PGND
	4	POWER GROUND	Power Ground.	PGND
	5	HIGH VOLTAGE	DC voltage input.	I

SWITCH FUNCTIONS:

SWITCH	FUNCTION DESCRIPTION	SETTING	
		ON	OFF
1	Internal voltage feedback	On	Off
2	Internal current feedback for IR compensation	On	Off
3	Current loop gain	Decrease	Increase
4	Inhibit Select	P1-11, 12, 13 : inhibit	P1-11, 12, 13 : enable
5	Current scaling. When OFF reduces both peak and continuous current limit by 50% (see section "G").	Full-current	Half-current
6	Can be used to reduce factory-preset maximum continuous current limit (see section "G").	Cont./Peak Ratio 25%	Cont./Peak Ratio 50%
7	It is recommended to leave SW7 in the OFF position.	Shorts out the current loop integrator capacitor	Current loop integrator operating
8	This capacitor normally ensures "error-free" operation by reducing the error-signal (output of summing amplifier) to zero.	Velocity / voltage loop integrator disabled	Velocity / voltage loop integrator enabled
9	Increases the value of the integrator capacitor. It is recommended to leave SW9 in the OFF position for most applications.	Increase	Decrease
10	Offset / test. Sensitivity of the "offset" pot. Used as an on-board reference signal in test mode.	Test	Offset

POTENTIOMETER FUNCTIONS:

POTENTIOMETER	DESCRIPTION	TURNING CW
Pot 1	Loop gain adjustment in voltage & velocity modes.	Increases loop gain
Pot 2	Current limit. It adjusts both continuous and peak current limit while maintaining their ratio (50%).	Increases current limit
Pot 3	Reference gain. It adjusts the ratio between reference signal and output variable (voltage, current, or velocity).	Increases reference input gain
Pot 4	Offset / test. Used to adjust any imbalance in the input signal or in the amplifier. When SW10 (DIP switch) is ON, the sensitivity of this pot is greatly increased thus it can be used as an on-board signal source for testing purposes. See section "G".	N/A

TEST POINTS FOR POTENTIOMETERS: See section "G".

SET-UP: See section "G" for engineering and installation notes.

OPERATING MODE SELECTION:

These modes can be selected by the DIP switches according to the chart in the functional block diagram:

- Current Mode
- Voltage Mode
- IR Compensation Mode
- Tachometer Mode

See section "G" for more information.

APPLICATION NOTE:

See section "G" for more information on analog position loop mode.

CURRENT LIMIT ADJUSTMENTS:

These amplifiers feature separate peak and continuous current limit adjustments.

The current limit adjusting Pot 2 adjusts both peak and continuous current limit at the same time. It has 12 active turns plus 1 inactive turn at each end and is approximately linear. Thus, to adjust the current limit, turn the potentiometer counter-clockwise to zero, then turn clockwise to the appropriate value. If the desired limit is, for example, 60 amperes, and the servo amplifier's peak current is 120 amperes, turn the potentiometer 7 turns clockwise from zero.

Pin P1-9 is the input to the internal current amplifier stage. Since the output current is proportional to P1-9, the adjusted current limit can easily be observed at this pin. Note that a command signal must be applied to the reference inputs to obtain a reading on P1-9. The maximum peak current value equals 7.25 V at this pin. If SW5 = ON, peak rated amplifier current = 7.25 V. If SW5 = OFF, 1/2 peak rated amplifier current = 7.25 V. Example: using the 120A10 with SW5 = ON, 120A = 7.25 V and with SW5 = OFF, 60A = 7.25 V.

The actual current can be monitored at pin P1-8.

The continuous current limit can be reduced without affecting the peak current limit by connecting an external current limiting resistor between P1-10 and P1-2. See table below.

CURRENT LIMITING RESISTOR	40K	20K	3K	1K	0K
CONTINUOUS CURRENT LIMIT	90%	80%	50%	30%	10%

SW6 (DIP switch) will reduce the continuous current limit to 50% of the maximum value, when switched ON. SW5 (DIP switch) will reduce the current feedback (monitor) scaling by 50%, thereby reducing both the peak and the continuous current limit by 50%, when switched OFF.

TYPICAL SYSTEM WIRING: See section "G".

ORDERING INFORMATION:

Model: 120A10X

X indicates the current revision letter.

MOUNTING DIMENSIONS: See page F-12